

Cold Rooms and Freezer Rooms

Cold rooms and freezers rooms are typically custom built and meant to store cargo items that occupy traditionally low temperatures. This includes products below freezing temperatures, as well health items that occupy the +2°C to +8°C range. Rooms with cold storage or freezer capacity typically are custom built for the storage requirement, and are subject to higher degrees of control, such as continuous monitoring capacity or redundant power systems. Cold and freezer rooms also require specialised equipment and insulation.

In the majority of operations, items requiring storage below +8°C usually make up a small portion of the overall volume of cargo items, and properly calibrated cold storage rooms often don't need to be large, and ideally should only match the actual known requirements. In many cases, a standalone electric refrigerator/freezer will meet the storage requirements for most agencies. Cold storage rooms can represent a substantial financial investment and given the duration of both emergencies and available funding, such rooms are typically only planned when either the volume of the incoming cold storage items are substantial, or when the duration of project is known to be long.

Walk-in cold room:

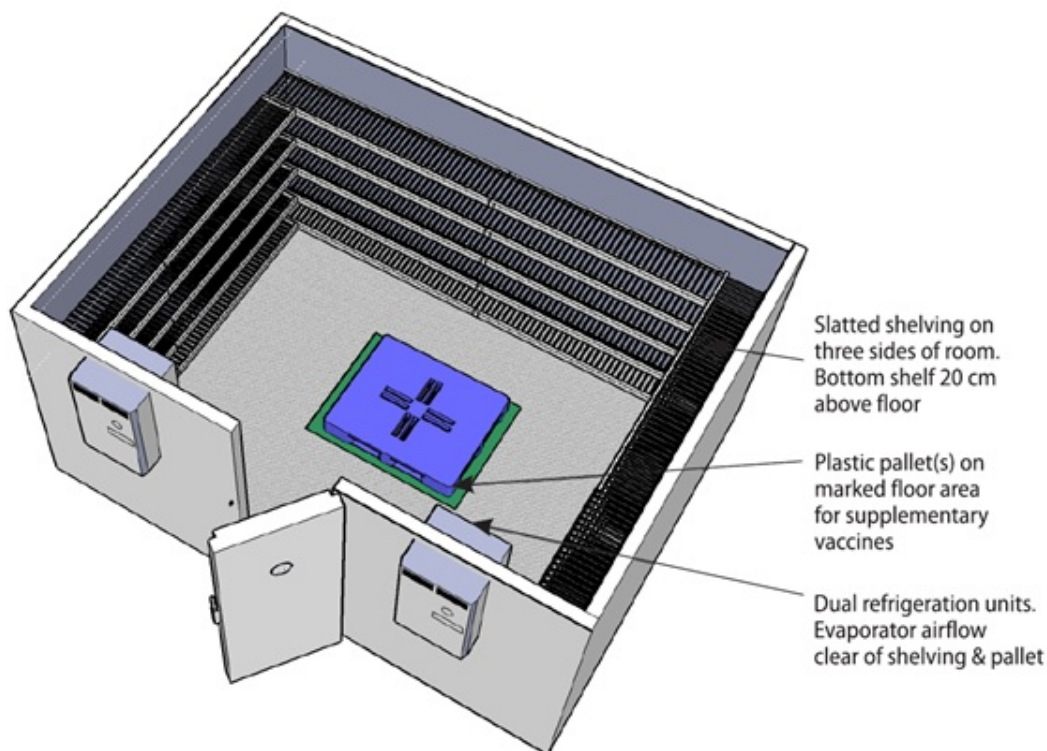

In instances where humanitarian agencies require large, or even warehouse sized refrigerated storage, it is strongly suggested that agencies speak with a licensed professional or attempt to outsource the storage space to a third party commercial provider. Large scale refrigerated storage or refrigerated warehouse spaces are fairly common amongst large manufacturers, or amongst national authorities, and their overall functioning is not dissimilar to smaller refrigerated storage spaces, however the costs and complexities associated with constructing and maintaining these facilities should only be overseen by experienced professionals.

In addition to industrial scale refrigeration, other features of refrigerated warehouses might include:

- A kitting or packing area – an area used to assemble pallets or kits that is also contained within a refrigerated space.
- Specialised doors/loading bays – doors and loading bays will have proper insulation, plastic flaps, or even specially designed fans to prevent heat loss through openings to the external world.

Temperature-controlled pallet standing storage area:

Pallet standing store

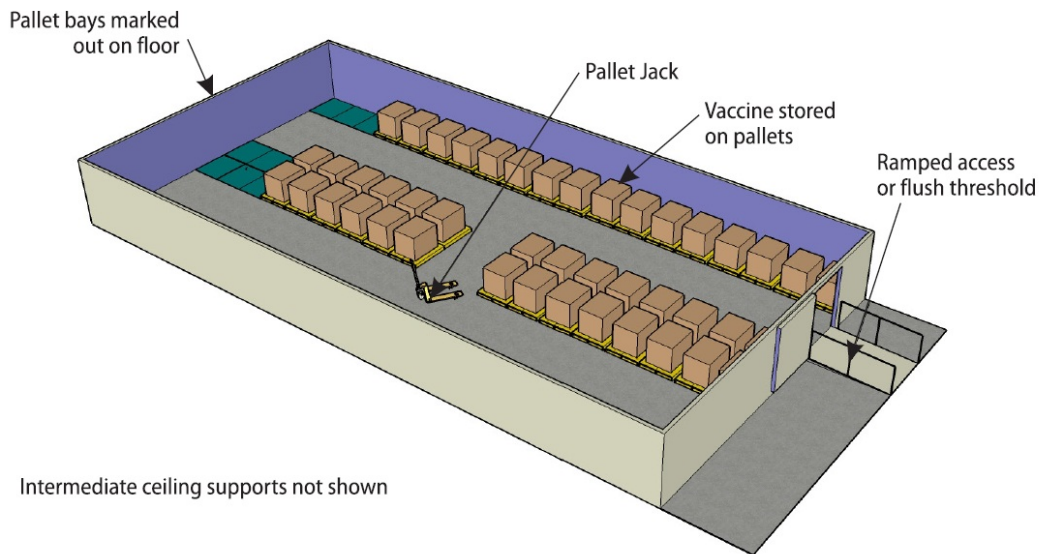

Temperature-controlled elevated racking storage with kitting/order assembly:

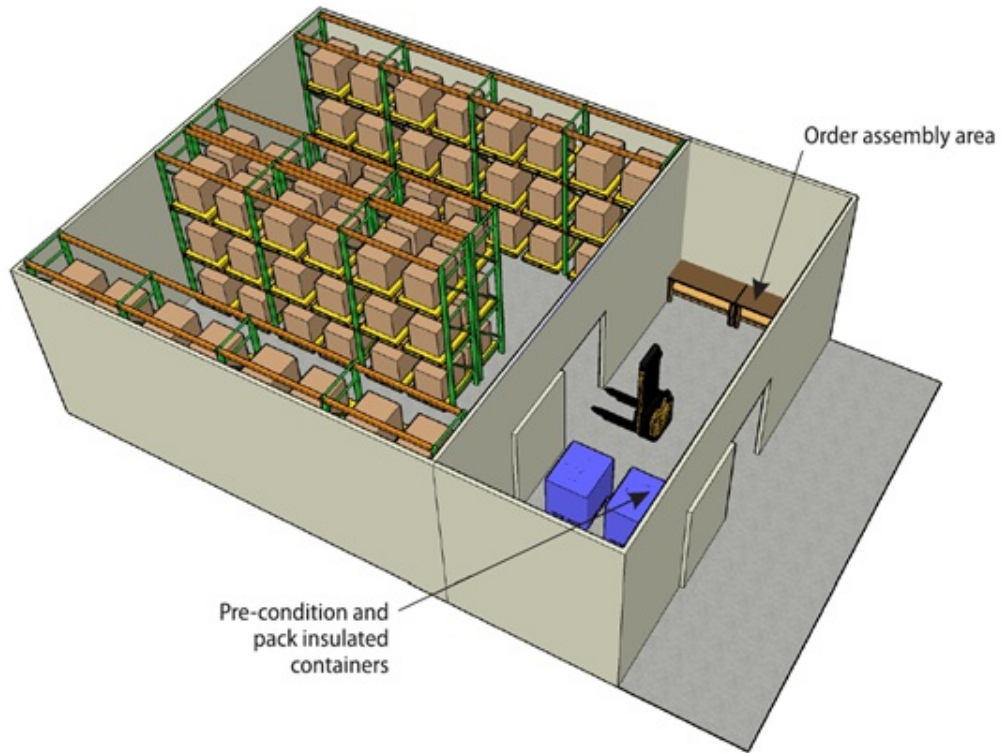

Temperature-controlled dock seal:

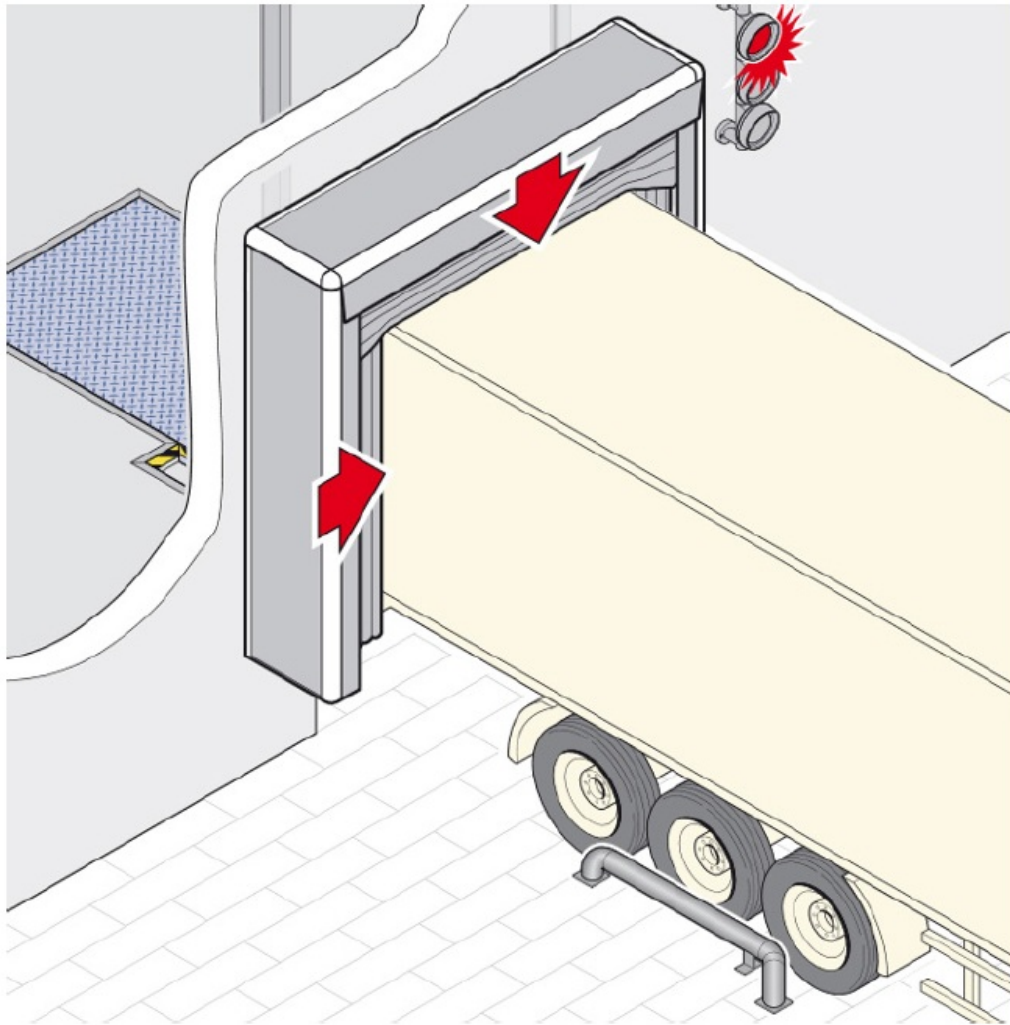

Taken from: [WHO - Design and procurement of storage facilities](#)

Stand Alone Refrigerators and Freezers

Some health commodities and some humanitarian health related storage needs may only require the usage of stand-alone freezers or refrigerators. Refrigerators and freezers tend to be useful for vaccines and other small volume pharmaceutical items, as the capacity of refrigerators is relatively small. However, refrigerators and freezers are good alternatives when the known quantities of stored items will be low volume, or when no other alternatives are available. Additionally, standalone refrigerator and freezers may be required for ice and cool packs if reconditioning of passive cold chain boxes is required.

Much like air conditioners, refrigerators and freezers also produce heat exhaust. If refrigerators/freezers are kept inside of a warehouse facility, there should be proper ventilation to avoid excessive heat built up, and planners should be aware of the impact increased temperatures might have on other collocated stocks. In instances where multiple freezers and/or refrigerators are in the same storage location, this may become a problem requiring dedicated attention.

Configurations for Refrigerators and Freezers

Though only basic equipment may be available in many field contexts, there are still special configurations that humanitarian organisations maintaining cold chain medical items may wish to consider.

Medical Grade Refrigerators/Freezers – There are a variety of medical grade freezers and refrigerators that are purpose built for maintaining keep cool and frozen grade medical items. Medical grade refrigerators and freezers are internationally regulated by WHO prequalification. Some characteristics of these refrigerator/freezer units might include:

- Highly calibrated thermostats/cooling units.
- Clearly defined set points.
- Back up battery systems in case of power failures.
- Alarm systems in case of temperature excursions.
- Clear windows to make identifying contents easier without having to open doors.

Specialty freezers and refrigerators are often also right-size, designed to only accommodate the anticipated demand of those specific temperature ranges, meaning they can be purchased in relatively small sizes, and different temperature requirements can be stored in different units.



Wherever possible, humanitarian organisations should avoid regular consumer grade refrigerators and freezers for any health items that have highly specific temperature ranges, or for health items that can be easily damaged by excursions. For example, vaccines tend to have a very low threshold for temperatures above/below defined ranges, and without clearly defined set points or precise monitoring a regular consumer grade freezer may not be sufficient.

If agencies plan on using regular consumer grade freezers or refrigerators, they will want to thoroughly assess the capacity of the units, including:

- Logging temperatures inside the for 5-7 days *prior* to storing temperature-controlled items to ensure that temperatures remain consistent and within the anticipated ranges. Monitoring should be done the same as a temperature-controlled warehouse –

temperatures logged once every few hours.

- If possible, agencies should use temperature loggers inside refrigerators/freezers to map any temperature excursions for functions.
- Install a universal power supply (UPS) with an alarm system in case of power outage.

Top Loading Refrigerators/Freezers – A common method for conserving power/preventing heat loss is the use of top-loading refrigerators and freezers. Top-loading units open from the top instead of the side – as cool air sinks downward, there is less of a chance of cold air escaping, maximising energy for the refrigerator or freezer. Much like consumer grade units, there are also medical grade top-loaded refrigerators and freezers that should be considered when procuring.



Persistent Power

Refrigerators and freezers require access to consistent power, especially when storing vaccines. Due to the fact that persistent power isn't always available in all field locations where humanitarian actors may be operating, there are a variety of power options that should be considered.

Compression Refrigerators: Plug-in Power – Basic refrigerators and freezers will come in plug-in models only, not dissimilar to those used in home settings. Some freezers and refrigerators specifically designed for management of vaccines and other medical commodities may come with built-in battery backup systems that enable the units to continue to maintain active cooling for periods of intermittent power outage. Built-in power backups generally won't provide power longer than a few hours, and users should consult manufacturer guidelines and compare against anticipated power outages in the areas of storage.

Absorption Refrigerators: Kerosene/Gas Powered – Completely off-grid refrigerators and

freezers traditionally have been powered with Kerosene and other forms of combustible gas. Gas powered refrigerators/freezers are typically powered using compressed gas cylinders or liquid gases – the gases are used to ignite a pilot light that heats permanently sealed coil that is chemically designed to produce a cooling effect. Gas powered refrigerators – though widely used – have slowly become less common due to the health risks and fire hazards associated with their use. Additionally, gas powered freezers/refrigerators will still require a supply of fuel, any disruption of which will cause the units to stop working. Depending on the size of the gas cylinder or the refrigerator units, gas powered refrigerators/freezers may need to be monitored and changed frequently.



Solar Powered – As costs of batteries and solar panels have gone down, the use of solar powered refrigerator units has increased in many remote areas. The basics of using solar power for refrigeration are no different than the basics of using solar for any other electrical appliance. For more information, please reference the sections on [solar powered systems](#) and [battery backup systems](#). The important things to note when using solar and battery systems for refrigerators and freezers is that refrigerators/freezers rely on electricity, and that the power is sufficient to match the consumption needs of the units – freezers and refrigerators tend to use a large amount of electricity, especially in warm climates.

In many cases, humanitarian organisations may wish to install solar panels and/or batteries specifically for standalone freezers/refrigerators; many manufacturers produce self-contained solar powered freezers and refrigerators that humanitarian organisations may buy. When investigating solar powered or battery backup supported freezers/refrigerators, it's important to note the difference between "Solar direct" power and "solar battery power".

- Solar Direct Power – the refrigerator/freezer is linked directly to the solar panel without any intermediary battery, meaning there is no electricity produced while the sun is not directly shining on the panels. Refrigerators/freezers that don't have built in battery backups will experience power outages during the nighttime.
- Solar Battery Power – Solar battery powered freezers/refrigerators have a regulated battery system in between unit and the solar panels, allowing the batteries to absorb power through the day and slowly disperse it through the night. A properly designed

battery backup system will accommodate the full need of the refrigerator/freezer, without any breakages in power, even during emergencies. A battery backup system should still have [sufficient safety controls](#), like any battery system in use.

Solar Battery Powered Refrigerator

Solar Direct Refrigerator

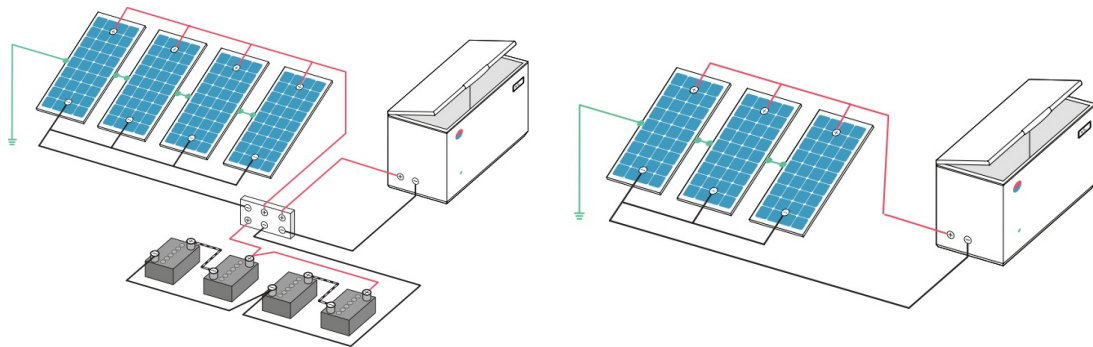

Taken from: [WHO - Solar direct-drive vaccine refrigerators and freezers](#)

In the event of persistent power outages/power shortages with no alternative provided for backup power, protocols should be put in place to ensure that goods stored within refrigerators and freezers maintain internal temperature during outages. This might include:

- Instructing staff to not opening the units while power is out.
- The use of temperature dataloggers.
- Using ice and cool packs to augment temperature controls.

Maintaining freezers and refrigerators

Refrigerators and freezers will degrade over time. Signs of degradation might include:

- Condensation or ice forming on the outside of the refrigerators.
- The compressor motor used to generate cooling runs for noticeably long or frequent periods of time.
- The interior of units never become cool, or reach a given set point.

Suggested maintenance procedures for medical grade refrigerators and freezers include:

- Keep units clean by regularly washing with mild soapy water solution.
- Keep door seals clean, avoiding build-up of material between folds and at corners.
- Remove build-up of ice (use the defrost system or a blunt scraper).
- Keep drains free of debris.
- Clean condenser coil (fins), ensure fins and cooling fan and any grilles are free of dust, fluff and debris.