

Managing Health Supply Chains

“ Well-supplied health programs can provide superior service, while poorly supplied programs cannot. Likewise, well-supplied health workers can use their training and expertise fully, directly improving the quality of care for clients. [...] An effective logistics system helps provide adequate, appropriate supplies to health providers, increasing their professional satisfaction, motivation, and morale. Motivated staff are more likely to deliver a higher quality of service”

[\(USAID - Logistics Handbook, A Practical Guide for the Supply Chain Management of Health Commodities\)](#)

Common Terms in Health Supply Chain

Set Point	The exact temperature refrigerated transport containers or storage containers are set at to accommodate the temperature control needs of the anticipated health commodities.
GXP/GDP	A set of standards for all supply chain actors involved to work with a common objective of ensuring product quality safety and efficacy when delivered to patients.
Excursion	Any variation above or below expected or accepted temperature ranges during the act of transporting, storing, or otherwise handling a healthcare item.
Cold Chain	The act of maintaining a set temperature across storage and transport throughout the entire supply chain, to ensure that temperature.
Temperature Monitoring	The act of continually monitoring the temperature of health items while in storage and transport.
FEFO	“First Expired / First Out” – A method of ensuring that the items closest to expiration are distributed and used first. FEFO is common practice in supply chain management of health items.
Recall	When a manufacturer or central health authority recalls specific health items, usually based on batch or production runs. Recalls impact all aspects of the health supply chain.
Medical Waste	Expired medication, used medical consumables, or any byproduct of medical activity that requires exceptional or specialized management.
Reefer Container / Truck	A truck or a container that has specialized, on board refrigeration capacity, including self-contained energy sources.
Passive System	Any system that maintains a temperature-controlled environment inside an insulated enclosure using a finite amount of preconditioned coolant in the form of chilled or frozen gel packs, dry ice, or others.

Active System	Externally powered or on-board powered systems using electricity or another fuel source to maintain a temperature-controlled environment. Common in cold rooms, refrigerators, temperature-controlled trucks, refrigerated ocean and air containers.
Refrigeration Equipment	Any equipment whose purpose is to lower air and product temperatures and/or to control relative humidity.
Temperature-Controlled	Any environment in which the temperature is actively or passively controlled at a level different from that of the surrounding environment within precise predefined limits.
Datalogger	Any device used to log temperatures of cartons or health items on an ongoing basis.

Responding to Health-Related Needs in Humanitarian Emergencies

When a humanitarian emergency occurs, the local health system may not easily cope with the increased demand for health services. The prevalence of high morbidity, epidemics, pockets of inaccessible populations, or simply new pockets of high population density, may require increasing the provision of health services.

Additional health services may be translated in different logistics activities; upgrading or extending existing health facilities, building temporary or semipermanent structures, provision of health products, dealing with medical wastes, urgent transfer of patients between different service levels or transport of samples to reference laboratories.

In all these cases, it must be considered that health services fall under the responsibility of local health authorities. Coordination and alignment with existing systems is therefore of paramount importance.

Regular health services provision and Health Care Supply Chains

Regular health service provision is often divided in different levels of care, referring to the complexity of the medical cases doctors treat and the skills and specialties of the providers. Levels are often divided into three or four categories:

- **Primary Care** - When a patient consults with your primary care provider.
- **Secondary Care** - When patient sees a specialist such as a traumatologist or endocrinologist.
- **Tertiary Care** - Specialized care in a hospital setting such as dialysis or heart surgery.

The health service package offered at a given level, including standardised treatment for specific diseases is usually harmonised across a given country or state. The selection of pharmaceutical products involves reviewing the prevalent health problems, identifying treatments of choice, choosing individually needed medicines and dosage forms, quantifying the medicine requirements, and deciding which medicines will be made available at each level of the health care system. The number and type of health facilities that will offer specific levels of care is normally linked with demographics. This normalisation across geography, demographics, and treatments, helps planning and designing the Health Supply Chains.

Most of public health supply chain networks operate as a centralised system, where a central medical store receives health products from manufacturers, and regularly supplies it downstream to several regional medical stores, while regional medical stores will supply subregional medical stores which will supply to hospitals and health centres in the subregion. The number of distribution levels will also depend on geography, demographics, and political divisions.

In some countries, vertical programs, or disease specific programs such as nutrition, malaria, HIV-AIDS or TB, may have a dedicated supply pipeline and parallel logistics systems. This is because, historically, they often have separate standard operating procedures, different funding sources or distribution channels managed by separate administrative units. Recently many countries have moved toward product integration, combining the management of some or all logistics functions for different commodity categories (- like family planning, HIV, malaria, and TB - into a shared supply chain.

All the considerations above said must be measured by humanitarian agencies when responding to health needs in emergencies.

General Concepts

Types of Health Commodities

“Health commodity” is a broad term that can refer to many items different in nature, and that may be needed for the provision of health services in humanitarian emergencies: scales, face masks, medicines, vaccines, preservatives, dressing material, alcohol used for medical procedures, needles and syringes, laboratory/diagnostic consumables, oxygen, etc. The sensitivity and stability of the product, the risks and the handling requirements, or the regulations for all these different items may be very diverse. The requirements for face masks or protective gloves are not the same as for medicines and vaccines so for an efficient and effective management of the supply chain, it’s important to know what products are being handled.

The most common terms used to define and categorise the types of health commodities are:

Medicine (Including vaccines)	Medicines can be defined as products including, but not limited to, finished pharmaceutical products, vaccines, and in vitro diagnostics (IVDs). A medicine is a substance or combination of substances that is intended to treat, prevent, or diagnose a disease, or to restore, correct or modify physiological functions by exerting a pharmacological, immunological, or metabolic action. Medicines usually have requirements for some level of temperature control, are usually considered fragile goods and often have requirements to limit light and humidity exposure. Vaccines are a subset of medicine products and are usually extremely sensitive to high or/and low temperatures.
Medical Devices (Reusable and Consumable)	Medical devices can be any instrument, apparatus, implement, machine, appliance, implant, reagent for in vitro use, software, material or other similar or related article, intended by the manufacturer to be used, alone or in combination for a medical purpose. This includes reusable medical devices (stethoscopes, forceps, endoscopes, surgical instruments, etc.) and consumable devices (needles, syringes, sutures, gloves, etc.).

Hospital Equipment	Hospital equipment can be any equipment, machinery, computers, tools, vehicles, software, furniture, or other infrastructure component used within a hospital or health facility environment. Hospital equipment generally does not have a temperature requirement but some of which may be considered fragile and have special requirements for transport (e.g. sensitive electrical equipment).
Laboratory Equipment	Laboratory equipment can include any support equipment or analytical instrument necessary to or involved in generating the results of a medical analysis. Some laboratory equipment have requirements for temperature control, are usually considered fragile goods and may have special requirements for transport of electrical components.
Therapeutic Food	Generally, includes ready-to-use therapeutic food (RUTF) and therapeutic milks (F-75, F-100) which are used in emergency response to manage acute malnutrition. Therapeutic food is generally not included in essential list of medicines or in other applicable essential health commodity lists, and therefore doesn't follow the same formal scrutiny as Medicinal Products. Although RUTF has been designed to resist harsh field conditions allowing management of malnutrition at community level, it always has an expiry date and exposure to high temperatures can accelerate the degradation mechanisms and reactions.

Packaging and Labelling

Packaging and labelling are integral parts of the medical products as it is where the specifications set by the manufacturer for handling and consumption are described, including the expiry date. Packaging of medical items serves to preserve the product from contact to the environment and its conditions. All printed material is considered part of the packaging and is registered as part of the regulatory requirements of the NDRA.

The product label should include the following information as appropriate:

- Name of the product
- Active ingredient(s), type and amount
- Batch number
- Expiry date
- Special storage conditions or handling precautions
- Directions for use, warnings and precautions
- Names and addresses of the manufacturer and/or supplier

The expiry date and storage conditions of pharmaceuticals and medical devices are determined by conducting stability studies to mimic different environments around the world, and by testing that medications still meet their expected quality control specifications after predetermined durations under those conditions. If a day/month/year is not printed as an expiration date, international best practice is that the item can be used up to and including the last day of the month mentioned.

Medicinal products are often packed and handled in several layers of packaging:

- **Primary packaging** – Primary packaging is in direct contact with the medicinal product, such as glass vial and rubber stopper, or blister foil. Primary packaging material is selected as part of the development process of a new medicine to assure its integrity, sterility (for injectable products) and to protect from humidity.
- **Secondary packaging** – Secondary packaging is the container into which the product in its primary packaging is placed to be delivered for distribution to healthcare workers. Often, this is a folding carton. For most medicines, a pack of a known quantity of the product

defines a “unit” for stock keeping purposes. Secondary packaging generally protects the product from light, vibration and physical shock.

- **Tertiary packaging** – Tertiary packaging is the container(s) into which, for most medicines, a number of units are placed for transport. Often this is known as a shipper carton. Tertiary packaging may also include insulated or thermal shipping containers.

Packaging materials in medicines are usually referred to as primary or secondary, with the difference being only primary packaging is intended to be in direct contact with the product. Tertiary packaging is not considered as part of the product.

There are strict regulations on the way medical products should be packaged and labelled. In emergencies, there may be a programmatic or operational rationale for repackaging or kitting/de-kitting of health commodities:

- Repackaging when it involves primary or secondary packaging is a manufacturing operation subject to strict national and international regulation and should be performed only at authorised premises (e.g. sterile) under the responsibility of a qualified person, or upon receipt at the health facility.
- Kitting/de-kitting which involves taking multiple secondary packages and repacking into different tertiary packages, (if it does not involve breaking down secondary packaging), is not considered pharmaceutical repackaging and can be conducted at the warehouse level depending on the national regulatory framework.

Health kits, as they are made up of a mix of items, have some modifications related to packaging and labelling on the tertiary packaging:

- Itemised packing lists should be included inside of each kit box, outside of each kit box, and on the pallet the kit(s) are shipped/transported on, with at a minimum: Name of the product, qty, batch number, expiry date, special instructions.
- Health kits are labelled with the “first item to expire” within the entire kit (even if the kit is more than one box/pallet).
- Health kits often have a separate batch/Lot number which identifies the entire kit from the supplier.
- Health kits should be labelled with the total number of tertiary packing (e.g. carton boxes) per kit and indicate the number of that specific tertiary package out of the total (e.g. box 7/12).
- If shipping multiple health kits per pallet, pallet wrapping should indicate the total quantity of each specific health kit for ease of receipt and inspection.

When planning logistics operation, it is of key importance to know what level of packaging is being mentioned, and the number of units per pack size, as volume and weight per unit may vary considerably. Incomplete or inconsistent information in the packaging of a medical product must raise suspicions and must be duly reported.

Regulated Commodities and Traceability

Though the regulation in each country may vary, the national regulations are established to ensure that only authorised goods are supplied to the population, and that the goods are supplied end-to-end, with minimal impact on their quality, safety, and efficacy.

Traceability constitutes a continuous product identification system throughout the entire supply chain. Every stakeholder involved in the pharma distribution has the obligation to start up, apply and maintain an effective goods traceability system to guarantee that, in case of a product constituting a serious risk to human health, the product can be withdrawn from the

market immediately. Clear identification of the products, including tracking product batch number throughout the whole supply chain is essential to safeguard traceability and enable item recall related reverse logistics. The principles of traceability help avoid the introduction of substandard or falsified (counterfeit) medicines into legitimate supply, as well as normalise which products are distributed and how.

As a best practice, all elements of distribution operations should be documented. Under local laws, all documentation pertaining to health items might be required to be made available for inspection by health authorities on request and may be required in the event of investigations or audits in the future.

Where national regulations are limited, or the urgency or the lack of resources do not allow surveillance of distribution activities, [WHO provides generic guidelines for the storage and distribution of medical products](#) that should be applicable where national regulations are limited, or resources or circumstances do not allow surveillance of distribution activities by local authorities.

Handling Requirements and Time and Temperature Sensitivity

Many medical items are classified as time-temperature sensitive products; products which lose efficacy, or may even become dangerous, depending on exposure to temperature conditions outside of the manufacturing guidelines. These items are called time and temperature sensitive, as the usability of the product after an exposure depends on the length of time of the exposure and how severe of an exposure was documented. Nearly all pharmaceutical products, most consumable medical devices and IVDs, and many sensitive medical equipment are considered time-temperature sensitive.

To ensure quality, safety, and efficacy of the product, the specifications set by the manufacturer (for storage, transportation, and distribution) must be well known and respected. Manufacturers' specifications, such as the storage ranges for temperature and relative humidity, come from very specific stability studies meant to identify the limits of the medical items. Not managing the medical items within those ranges will lead to quality issues and may cause harm to patients. In addition, certain items are light sensitive and hence require appropriate packaging and avoidance of direct exposure to light to prevent item degrading or damage. Furthermore, the respect of handling requirements such as hygiene, avoiding degradation of the items, follow up of expiry dates and traceability are also often included in the legal requirements expressed by national regulatory authorities.

The most common temperature ranges used for handling of medical products are:

Temperature Range	Common Name
+15°C to +25°C	"Controlled ambient" or "Temperature-Controlled"
+8°C to +15°C	"Cool"
+2°C to +8°C	"Cold" or "Chilled" or "Refrigerated"
-25°C to -15°C	"Deep freeze" or "Frozen"
different ranges between -80°C to -40°C	"Ultra-low"

Terms like "ambient", "room temperature" and "cold chain" should be avoided when describing storage and handling needs as a whole, or when used as the only labelling for storage or transport of boxes/containers because these terms are not always clear and might have different meanings in different parts of the world. It is always better to indicate the temperature range to avoid confusion on the nomenclature when labelling goods or providing instructions for management considerations. General differences in nomenclature around the world might include:

Terminology	WHO	European Pharmacopoeia	US Pharmacopoeia	Japan Pharmacopoeia
Frozen/ deep-freeze	-20°C	>-15°C	-	-
Refrigerator	-	+2°C – +8°C	-	-
Cold	+2°C – +8°C	+8°C – +15°C	<+8°C	+1°C – +15°C
Cool	+8°C – +15°C	+8°C – +15°C	+8°C – +15°C	-
Room temperature	+15°C – +25°C	15°C – +25°C	temperature prevailing in a work area	+1°C – +30°C
Controlled room temperature	-	-	+20°C – +25°C excursions between +15°C and +30°C are allowed	-
Ambient temperature	+15°C – +25°C or +30°C depending on climatic conditions	-	-	-

Adapted from ECA Academy "Regulatory Definitions for "Ambient", "Room Temperature" and "Cold Chain"

Storage conditions are always better explicitly specified in terms of a defined temperature range (e.g., +15°C to +25°C or +2°C to +8°C). Particular attention should be given to avoiding freezing of liquids and semi-solids.

It is a common regulatory expectation to keep track of temperatures at which products have been stored. Keeping records of expiry dates and batch numbers is also a GDP requirement.

Set Point – A set point is a term that is frequently used in both storage and transport of temperature regulated items. A set point is defined as the temperature at which a powered refrigerated storage or transport container is configured to keep the goods in the desired temperature range. A set point of +5°C is often used in appliances for storage or transport between +2°C to +8°C, letting +/- 3 degrees C of margin before experiencing a temperature deviation.

Temperature Monitoring – Monitoring of health times refers to the manual or automatic method of monitoring and tracing the temperature environment of health items while in storage or in transit. There are a variety of monitoring techniques and equipment, and their use will depend on the nature of the transported goods, the local infrastructure, and monitoring requirements put in place by national authorities.

Temperature Excursions

A temperature excursion is defined as any deviation from pre-defined specific temperature range for a product during storage, transport, or handling. Temperature excursions can be caused by faulty equipment not regulating temperature, improperly set equipment, or items being handled transported or stored under inappropriate conditions. Excursions can be caused by relatively simple things, such as a door to a refrigerated container being left open for too long during loading or unloading, or a vehicle being parked in a sunny spot. Generally, temperature excursions are informed by temperature monitoring equipment that log the extent or duration of the excursion, however even without monitoring equipment excursions can be noted using common sense, such as identifying temperature regulated cargo left in the sun.

The response to an excursion depends on the severity of the excursion, and on the nature of the impacted goods. Routine basic pharmaceuticals that experience a temporary excursion may not require extra special attention, while refrigerated vaccines exposed to the same excursion may be considered completely unusable. In the event of an excursion:

- The personnel transporting or managing storage of the temperature regulated health items should take note of the excursion, and make a physical written record as required by your agencies protocol.
- The senior logistics or supply chain manager should be notified, who will need to take the appropriate action within your organisation's rules and regulations for quality risk management:
 - A quality assurance specialist or focal point may need to be sent the documents which outline the deviation (e.g. datalogger information) to advise on the usability of the product and/or instructions.
 - Depending on the end use of the items, the ultimate consignee might need to be notified of any temperature excursions along the supply chain.
 - In some contexts, local or national health authorities might need to be notified of any temperature excursions.
 - The staff pharmacist or health program manager may need to be notified to take appropriate actions.

In severe cases, agencies may need to contact the manufacturers of the health items to understand how to best handle the situation.

- The cause of any temperature deviation should be documented, and mitigation measures should be implemented immediately to avoid future damages to additional products.

In the event that a temperature deviation results in an unusable product the logistics or supply chain personnel may need to dispose of the item in line with national medical waste management protocols. This may involve reverse logistics.

Regulatory Frameworks for Health Supply Chain

A specific component to health supply chains that is frequently overlooked or underestimated by humanitarian organisations is the overall regulatory framework in which management of health commodities resides. Different operating contexts will have extremely different regulations and laws governing the procurement, storage, transportation and distribution of pharmaceuticals and other health items. In many contexts special certifications or permits are required to even handle health items, and in some cases humanitarian agencies may outright be incapable of managing their own health supplies without utilising an accredited third party.

Over the past few decades there has been increasing attention to how health items are

managed on both a national and international level, and many traditional humanitarian emergencies may now be facing stricter regulations than before. Alternately, some humanitarian contexts have virtually no local or national regulations pertaining to the management of health items, and responding organisations must do their best to maintain a minimum level of quality for the management of health items.

Humanitarian organisations should be aware of local regulations when they begin a health-related project in any given country and should consult with national or local Ministries of Health, Food and Drugs Administration Authorities and National Drug Regulatory Authorities, or other relevant ministries about the prevailing laws and regulations prior to beginning activities.

Good Distribution Practice (GDP) for Medical Products

Good Distribution Practice (GDP) is a set of standards for all supply chain actors involved to work with a common objective of ensuring product quality safety and efficacy when delivered to patients. GDP applies equally to forward supply, to reverse logistics, to commercial supply chains, to private and public health supply chains, whether items are procured directly or donated. The objective of adherence to GDP is to ensure that goods are supplied from the manufacturer to the population with minimal impact on their quality, safety and efficacy, and to ensure the avoidance of infiltration of falsified, counterfeit or substandard products into legitimate supply chains. GDP is the responsibility of all actors' participants in the distribution process to ensure that procedures are designed to protect the products and the recipient population.

GDP encompasses many aspects of the management of pharmaceuticals and health commodities that humanitarian organisations might encounter, however there are many other categories of quality assurance management for categories for health supply chains, including:

- Good Manufacturing Practice (GMP)
- Good Pharmaceutical Practice (GPP)
- Good Storage Practices (GSP)
- Good Trade and Distribution Practice (GTDP)



Often, the different special categories of practice are all labelled as GDP. The specific nomenclature is not as important to humanitarian actors – the important part is that humanitarian organisations managing a supply chain of health items understand what their obligations are, based both on the type of commodities and the prevailing regulations in the context of operation. The point of a GDP is to ensure that the following components of a health supply chain are adequately planned and developed:

- Traceability and Inventory Management.
- Necessary Equipment.

- Storage and Transport Standards.
- Documented procedures.
- Responsibilities for GDP set out in job descriptions.
- Quality risk management.
- Management of Outsourcing.
- Management of Change, Deviations and Corrective Actions and Preventive Action (CAPA).
- Self-inspections.
- Systems for handling returns, complaints and recalls.
- Notification to senior management of GDP compliance and performance.
- Training of personnel.

The World Health Organisation (WHO) [maintains detailed guidance on GDP](#) that is regularly updated, and is available to all healthcare practitioners. However, many countries and national authorities maintain their own specific GDP requirements that vary from context to context and require their own study and compliance. Many Ministries of Health (MoH) produce publications or maintain websites with regulations and resources available for the public - Humanitarian response organisations should inquire about GDP regulations in any context in which they operate prior to enacting procurement or establishing health activities.

Procurement and Sourcing of Medical Items

Unlike sourcing many routine humanitarian relief items – such as durable goods or NFIs – the procurement of health items comes with many of its own caveats.

Registration of Pharmaceutical Products - In most countries, companies that produce, import and sell pharmaceutical products are required to obtain prior evaluation and approval from a governing body, often called the national drug regulatory authority (NDRA), or a stringent regulatory authority (SRA). Products to be registered should be proven to be effective, safe, and of good quality. Registration is often also called Marketing Authorisation (MA). Due to the fact the quality of the medications is checked as part of the registration process, each brand (produced by different manufacturers) is registered independently. In most cases, not only the product, but also the packaging, is registered. National Marketing Authorisation often have limited validity and must be renewed with certain periodicity. Pharmaceuticals intended for import as part of the humanitarian assistance (for non-commercial use purpose) may be exempted from registration of pharmaceutical product in the host country. It is important not to assume this will be the case and verify details with respective authorities in country prior to the dispatch of goods.

Essential Medicines List - Each country defines its own essential list of medicines (EML), aiming to satisfy the priority health care needs of its own population. Essential medicines are selected with in reference to disease prevalence and public health relevance, evidence of efficacy and safety, and comparative cost-effectiveness. Essential medicines are intended to be always available within the context of functioning health systems in adequate amounts, in the appropriate dosage forms, with assured quality and adequate information, and at a price the individual and community can afford.

The World Health Organisation (WHO) maintains what it calls the ["Model List of Essential Medicines"](#), a list of formally recognised medications that WHO reviews and endorses for usage for populations around the world. The model list of essential medicines is reviewed every few years, and medication is either added or removed based on advice derived from the most up to date clinical data. The contents of the model list are [searchable via an online database](#). The model list of essential medicines is not the definitive list of usable drugs in all contexts, nor is the list of all approved drugs – it merely serves as guide for national authorities, manufacturers

and importers to reference. More information on how national level essential medicines are developed can be found in WHO's guide on the [Selection of Essential Medicines at Country Level](#).

The majority of countries in which humanitarian organisations operate have adopted at least part of the model list of essential medicines, but it is very common for countries or national authorities to add or remove medications to the list to cover their own importation needs. Countries may choose to add or remove medications for sociocultural or political reasons, and some countries or regions have extremely robust and complex regimes for defining acceptable medications and dosages.

“ Many pharmaceutical products can be registered for use in a country, but they may not be on the national EML, or on the standard treatment guidelines. Products not on the EML, but used by the private sector, can still be registered if their efficacy, safety, and quality are acceptable to the regulatory authority. Failure to follow the pharmaceutical registration protocol could lead to products being held up by customs when they enter the country. Not only does this delay the delivery of important health care products, but it wastes time and money, and risks spoilage or expiry of products while at customs.”

[\(USAID - The Logistics Handbook, A Practical Guide for The Supply Chain Management of Health Commodities\)](#)

National Drug Regulatory Authorities may also normalise where health products are sourced, in what shape and dosages are presented, what minimal identification and use indications shall be provided, etc.

It is often considered that the procurement is the crucial point of Quality Assurance (QA) of medicines. The source of the raw materials (active ingredient, excipients - an inert substance used to give a pharmaceutical preparation a suitable form or consistency), as well as the way the final pharmaceutical product is manufactured determines the intrinsic quality of each medicine.

Donor Regulations

A significant portion of funds used to procure health related items in an emergency comes from large scale institutional donors. Many donors have well established procedures on what and how medicines and medical support devices can be purchased using their funds.

Most major institutional donors only allow recipients of their funds to procure pharmaceuticals through pre-qualified suppliers. Pre-qualified suppliers must undergo thorough audits and must be regularly reviewed for their quality assurance standards. As a result:

- There are a limited number of pre-qualified suppliers globally, and frequently they are outside the areas of the emergency.
- Different donors don't always pre-qualify the same supplier; If an aid organisation receives funds from more than one donor, they may be obliged to buy from different sources depending on the funding type.
- Some pre-qualified vendors function as non-profits, while others are commercial enterprises. This may impact product costs and availability.

The variability and geographic specificity of donor pre-qualified vendors mean that humanitarian organisations should research their relevant donor regulations prior to purchasing pharmaceuticals and other health items. The relatively small number of suppliers also means that procurements will likely need to be imported – please reference the section on

[Importation and Customs](#) for more information.

Product Names

“ *The selection of the medicines to be provided in a country affected by an emergency is of key importance because, if the medicine is not well known by the health professionals who will prescribe it, it will not achieve its intended use.*”

[\(DG ECHO - Review of quality assurance \(QA\) mechanisms for medicines and medical supplies in humanitarian aid\)](#)

Sometimes pharmaceutical items can be referred to by a variety of names. When ordering drugs please consider the following points.

International Non-proprietary Name - An international non-proprietary name is a unique name that is given to the product based pharmaceutical substances or active pharmaceutical ingredients and is generally globally recognised.

Brand Name - For marketing purposes, brand names are generated by a particular manufacturer and will generally be trademarked. All brand name products will still carry an international non-proprietary name as well, as there should be no difference in chemical composition from one brand to the next. Some pharmaceuticals that hold brand names may still be under patent by one Manufacturer. These products are usually given patent protection for 20 years from the date the patent was submitted and provides protection for the innovator of the medicines to recover the initial costs incurred in research development and marketing expenses.

Generic Drug - A generic drug is a pharmaceutical that is produced and distributed without patent protection. It has the same active ingredients as brand names, but it can be manufactured by a different producer.

It's strongly recommended to use international non-proprietary names to refer to medicinal products. Using the international non-proprietary names enables you to purchase products from multiple suppliers, whether branded or generic, and manage them as the same product.

Health Kits

A common procurement strategy for health items in humanitarian emergencies is the design and use of [emergency health kits](#). These standardised kits of medicines and medical supplies are developed by agencies to meet different health needs in humanitarian emergencies and disasters during the acute emergency phase, normally during the first 3 months, when [a push model](#) is critical to launch the operation. It's key to note that after the acute phase of an emergency is over, or during chronic emergencies, the quantity of needed medicines should be reassessed base on operational needs, and a routine supply of health items should come from consumption-based demand.

The most widespread and accepted emergency health kit is the [Interagency Emergency Health Kit \(IEHK\)](#) developed by WHO, however there a variety of other kits that support trauma surgery, maternal and reproductive health, newborn health, and specific infectious diseases produced and managed by different humanitarian organisations. Emergency health kits may include a mix of pharmaceuticals, medical devices and equipment, and are designed based on treatment of specific medical conditions common in emergencies. The contents of each kit are designed to attend specific diseases, for a specific number of patients during a given period of

time using assumptions based on global standard treatment protocols.

The advantage of emergency health kits is that they are uniformly recognised and stocked across multiple organisations and vendors and are generally recognised by governments. A pharmaceutical manufacturer or supplier can assemble, or stock health kits based on known and pre-approved components, and customs and health officials at the national level have known documentation on what may be included. Depending on the organisation responsible for the specific kit(s), content is usually updated every few years to be compliant with updated clinical guidelines and based on other changes in the medical supply landscape.

Use of the word “kit” should not be mistaken as a singular box or bag. The majority of health kits consist of more than one box, and in some cases multiple pallets per single kit. Additionally, a number of health kits contain a mix of health product categories – such as temperature-controlled items, keep cool items, dangerous goods, or controlled substances – and management of health kits requires keen attention and the implementation of quality risk management throughout distribution.

Some larger humanitarian organisations may choose to develop their own health kits, which may or may not be available to other agencies for procurement. Prior to developing health kits, agencies should consult what is available on the market, and keep in mind the need to conform to international standards, such as essential medicines lists, while doing so.

Advantages of Pre-Made Health Kits

Disadvantages of Pre-Made Health Kits

-
- | | |
|---|---|
| <ul style="list-style-type: none">• Kits are pre-defined for specific health emergencies and reduce the complexity of ordering on short notice.• Kits are useful when beneficiary data is limited, and no proper demand is fully understood – this is very common in the early phases of emergencies.• Kits are fast to order – vendors have well defined and premade kit contents, and sometimes even stock them in advance.• Kits are fast to distribute – in many cases, kits will arrive in clearly marked packages, and already be segregated into easy-to-handle cartons. Kits also don't require field level users to break down and re-kit larger bulk orders. | <ul style="list-style-type: none">• Kits don't always fulfill the supply needs for comprehensive services and tend to only target lifesaving needs for specific medical practices.• Kits are designed based on global averages on prevalence of clinical interventions for low- and middle-income settings, and assumptions on supply requirements for each clinical intervention based on WHO treatment protocols. As a result, the kits are not based on the national treatment protocols in a specific country or on the specific service seeking behavior of the targeted population.• Kits in their design are inherently more expensive than bulk procurement of the items contained within the kit.• Kits may have a shorter shelf life. Many kits are held in stock at the global level prior to dispatch to a specific country, and the shelf life of individual items in the kits will be shorter than items with expiration dates taken from regular vendor rotation. |
|---|---|
-

Donations of Medicines and Health Supplies

There are many different scenarios for medicine and health material donations – such as emergency aid, long- term aid, or assistance to national health systems or to individual health

facilities. Donations may come from pharmaceutical companies (directly or through private voluntary organisations), they may come in the form of aid from governments, or they may be donations aimed directly at single health-care facilities. The intended beneficiaries of donations of medicines range from individual facilities to entire health systems. Although there are legitimate differences between these scenarios, many basic rules for appropriate donation practice apply to them all.

WHO in cooperation with major international agencies active in humanitarian relief and development assistance, developed the [Guidelines for Medicine Donations](#). The guidelines are intended to improve the quality of medicine donations in international development assistance and emergency aid.

The guidelines aim to describe a common core of good medicine donation practices based on a few core principles:

1. Donations of medicines should benefit the recipient to the maximum extent possible. All donations should be based on an expressed need. Unsolicited medicine donations are to be discouraged.
2. Donations should be given with due respect for the wishes and authority of the recipient, and in conformity with the government policies and administrative arrangements of the recipient country: all donated medicines or their generic equivalents should be approved for use in the recipient country and should appear on the national list of essential medicines or equivalent or in the national standard treatment guidelines, if the national list of essential medicines is not updated.
3. There should be effective coordination and collaboration between the donor and the recipient, with all donations made according to a plan formulated by both parties.
4. There should be no double standard in quality. If the quality of an item is unacceptable in the donor country, it is also unacceptable as a donation.
5. Items must not have less than minimum required shelf life upon arrival to allow timely distribution and consumption without causing unnecessary reverse logistics activities and related costs.

Different humanitarian organisations will have internal requirements and processes for the acceptance of donations of medical and health supplies which aim to ensure compliance with WHO guidelines for medicine donations.

Importation and Customs of Medical Items

In addition to the [regular procurement policies and procedures](#) used for importing goods in any humanitarian context, there are additional components specific to the importation process of pharmaceuticals and health items that humanitarian organisations should be aware of. The importation of pharmaceutical products is normally done in compliance with national regulations established under the National Medicines Regulatory Authority (NMRA). In most countries, NMRA is the national agency responsible for the marketing authorisation of, and other regulatory activities concerning pharmaceutical products.

In principle, the NMRA will restrict the importation of unapproved and substandard medicines, as this poses a serious risk to public health. For controlling purposes, specific requirements are expected for the importation of goods such as medicines, vaccines and biologics and medical devices and other health supplies (not exhaustive: will depend on local regulations):

- Only designated ports or points of entry specifically authorised for importation may be used to channel consignments of pharmaceutical products.

- Only pharmaceutical products proved by appropriate documentation to be duly licensed for marketing or specific intended use such as clinical trials, personal use or other means as appropriate should be cleared by customs. When new products are required for importation, an emergency authorisation must be released by the local authorities.
- All importation of pharmaceutical products may be done by authorised importers only.
- Quality sample testing may be required, being unable to release the goods until the results are provided. In some cases, testing occurs at the time the goods arrive, or even after they have cleared customs.
- Specific requirements may be put in place related to minimum shelf life on importation.
- Additional restrictions and licenses may be imposed for importing different narcotics (controlled substances) and [dangerous goods](#).

In addition to restrictions on importation, many times NMRA's or other authorities might also restrict the export of certain health items as well. Requirements for restriction of exportation may vary, depending on sensitive local markets, politics, or regulations on controlled substances. Exportation restrictions may impact reverse logistics of removing drugs but may also impact drugs exported from manufacturing or prepositioning facilities in more developed countries as well. Importers/exporters should review legislation requirements prior to exporting any items and should consult with a knowledgeable customs broker.

Emergency Procedures for Import

In emergencies, import regulations may change. Depending on the type of emergency and the political climate, the regulations on import might change substantially; when confronting a major natural disaster or health emergency such as a pandemic, the authorities are prone to be more flexible with their importation procedures. By contrast, emergencies caused by political instability may cause the rules and regulations to become more challenging and the paperwork more burdensome.

The type of registration obtained by the humanitarian organisation may affect its ability to import medicines in case of an emergency.

- If organisations are registered under the ministry of health as a medical NGO, importation of medicines and health products may become easier.
- Declaration of non-commercial use of the products, or the donation to the Ministry of Health may also ease the process.

Waivers in emergencies specific to health supply importation (depending on the context) may include:

- Waivers on importation based on NDML.
- Waivers on importation based on national registration.
- Reduction on documentation and testing requirements.
- Waivers on restrictions to country of origin.
- Waivers on restrictions of import to specific ports of entry.
- Waivers on restrictions of authorised importers.
- Waivers on minimum shelf life requirements (If required for advocacy: see attached Appendix 2 to the WHO Points to consider for setting the remaining shelf-life of medical products upon delivery, which specifies for governments examples of minimum remaining shelf-life for emergency health kits for use as part of humanitarian response).

Customs Concepts Common to Health Items

Banned/Allowed Items

Prior to attempting to import any pharmaceutical or health item into any country, humanitarian organisations should research regulations on what can and cannot be imported. This is especially important in rapid emergencies where organisations may wish to import pre-made kits or prepositioned stock or undertake a rapid procurement that may or may not contain items that are not permitted to be imported for whatever reasons.

Methods that humanitarian organisations can use to identify banned/allowed items for import include:

- Speak with a registered customs broker.
- Consult ministry of health websites or other online sources.
- Reference [the database of approved essential medicines per country](#).

Documentation:

In addition to the regular documentation required to import any item, there are additional documentation or steps that may relate to health items, with particular emphasis on pharmaceutical and live vaccines. These might include:

- **Certificate of Registration** – Proof that the medicinal product is duly authorised by, to be marketed or otherwise so authorised for use in clinical trial or for personal use.
- **Import License** - Proof the importer is duly authorised to undertake the transaction.
- **Certificates of Analysis (CoA)** – CoAs include information on laboratory testing for specific batches or lots of pharmaceuticals and other health items. Sometimes CoAs can be provided by the manufacturer, but some national authorities require CoAs from recognised outside sources to prevent fraud.
- **Laboratory Samples** – Some customs and health authorities require laboratory testing on imported goods once they arrive in-country. This usually entails samples taken from supplies prior to clearing customs and being sent to state managed or mandated laboratory testing sites.
- **Other Common Forms** – Safety Data Sheets (SDS), Certificates of Origin (CoO), Certificates of Inspection (CoI), Certificates of Conformity (CoC), Pre-shipment Inspection (PSI) as applicable. More information on other common forms [can be found here](#).

Cold Chain Items:

For cold chain products, there may be fast track procedures, enabling a preliminary reception of the goods while clearance procedures are concluded at a later stage. In any case, for any temperature-controlled range, it is strongly recommended to assess the customs facilities for their capacity to receive and properly handle items.

Transit Regimes:

Many countries now have strict regulations on handling health items under their own national GDP, and health items may only be released to a limited number of pre-identified entities, such as central medical stores or state appointed companies. In instances where humanitarian organisations may wish to transit health items through one country into another neighbouring country, there may be limitations on the types, quantities, or time frame in which some or all health items can transit.

Physical Considerations:

Depending on the port of entry used for importation of medical items, there will be different

infrastructure available and different levels of knowledge on the handling staff related to medical supplies.

In larger centralised airports and sea ports, where the private/public sector have already been importing medical supplies, the likelihood is higher that the correct temporary storage infrastructure, handling equipment, standard operating procedures and capacity of handling staff is in place.

In smaller air and sea ports, or in locations where the entry point operation has been impacted by the emergency - such as damage to infrastructure or displacement of handling staff - there may be gaps in the proper infrastructure, capacity, and processes related to maintaining the safeguarding and quality of medical supplies.

Bottlenecks or gaps, which need to be mitigated for, may include:

- Lack of available (or insufficient space in) covered storage location.
- Lack of available (or insufficient space in) temperature-controlled storage (or reefer connectors in sea ports).
- Lack of available (or insufficient space in) keep cool storage locations (or reefer connectors in sea ports).
- Lack of knowledge of handling staff on fragile goods handling.
- Lack of proper handling equipment.
- Lack of special operating procedures within standard operating procedures dedicated to offloading and immediate temporary storage of medical supplies in relevant storage locations.
- Lack of controlled access storage for controlled substances.
- Lack of process or infrastructure for segregation, destruction or movement of damaged/expired medical supplies (pre or post clearance).
- Lack of knowledge on preparation of keep cool items for onward dispatch when cleared.

Solutions, which will often require engagement with relevant national authorities and port operating agents may include capacity development of personnel, procurement of ad hoc infrastructure/equipment (temperature controlled MSUs, refrigerated containers, freezers, generators, etc.), or deployment of dedicated specialised personnel to the entry point.

Storage Facilities for Medical Items

There are special considerations in the storage and management of health products. Health supplies have specific characteristics which may increase their risk of damage (e.g. fragile, temperature sensitive, light sensitive, flammable), which may increase the risk to beneficiaries if not stored properly. Ensure warehouses selected can, in general:

Store medicines/medical supplies appropriately in line with manufacturer labelling. This may include:

- Keeping items away from direct sunlight.
- Regulating the humidity in the storage area.
- Maintaining proper temperature for different products.
- Storing medical supplies separately from chemicals or food (pesticides, fertilisers, cement, fuel included), and dangerous goods. This also applies when loading onto vehicles.
- Storing narcotics and high value items in a secure location, in line with national rules and regulation.

Practice proper basic inventory management and tracking, including:

- Storing items in rational manor (e.g. organised by type).
- Taking regular temperature checks of different storage areas.
- If stored on pallets, clearly labelling all cartons with their contents.
- Keeping proper records on bin cards and in inventory logs - always including batch numbers and expiry dates upon receipt and record batch references at all stock movements, including on all stock/bin cards and all warehouse ledgers.
- Using and understanding First Expire First Out principles (FEFO).

Manage safely expired and damaged products:

- Quarantining expired or damaged drugs until they can be safely destroyed.
- Keeping a record of drugs placed in quarantine on the relevant bin and stock cards.
- Having a process for expired/damaged items. These drugs/consumables should be destroyed safely in line with WHO and national government regulations.

A temperature-controlled storage area is any place in which the inside temperature is consistently maintained within a predefined temperature range.

Humanitarian working conditions often have limited or no temperature-controlled storage capacity, so the need for temperature-controlled conditions must be factored into operational plans when selecting and establishing storage. Any form of temperature-controlled space will require basic equipment – air-conditioners, refrigerators, freezers – and some form of power, most commonly electricity, generator, or solar based solutions. It is essential to look at specific packaging and labelling requirements of specific products and obtain this information ahead of receipt of goods.

The majority of health items with time-temperature sensitive conditions used in a humanitarian environment require storage between +15°C to +25°C. However, a critical component of the medical supply chain will require +2°C to +8°C storage, including lifesaving drugs, blood transfusion items and some vaccines. In special cases, including outbreaks of infectious diseases, or where specific medical interventions are planned, other temperature categories may be required.

Depending on the outside ambient temperature, it may be essential to specifically contract/modify storage spaces to have dedicated temperature zones within warehouses. Specific infrastructure, equipment and power solutions need to be considered in planning and the design of warehouses.

Temperature Zones

A “temperature zone” is any discrete area inside of a storage facility that has a measurable temperature different than other parts of the same warehouse or storage facility. Temperature zones are usually caused by warmer air rising to the top of a warehouse causing stratification, however temperature differences can also be caused by proximity to doors and windows, pipes or running equipment that may radiate heat.

Temperature stratification is the process of heat separating in an enclosed space – warmer air

rises, and in larger facilities the temperature differential between the bottom shelf and a top shelf can be both noticeable, and cause damage if left untreated for a long time. Temperature stratification can be prevented by installing fans or air conditioners that are specifically designed to rotate air, or by intentionally limiting the height of storage for smaller facilities.

Humidity can also be a problem in some climates, and where required electrically powered dehumidifiers can also be installed. Logistics planners should note that primary packaging materials are chosen to protect the medicine from expected humidity in the climatic zone where the product is to be used, so requirements for controlling humidity may be dependent on product types and product sourcing.

For ranges above freezing, temperature is most efficiently controlled by a balanced combination of active and passive techniques. Depending on the climate, these are likely to include:

Insulation	<ul style="list-style-type: none">• Install high quality insulation on the walls inside of the storage structures.
Self-Contained Room	<ul style="list-style-type: none">• Build an internal cold storage room within the facility. Ideal standalone cold storage rooms will have an airgap surrounding it to increase insulation. Airgaps should be situated in a way to prevent airflow through the open space.
Minimise Heat Gain/Loss	<ul style="list-style-type: none">• Close or Minimise gaps around doors and windows.• Ensure that doors are only open as long as necessary.• Use plastic flaps over cargo doors.
Passive Techniques	<ul style="list-style-type: none">• Use natural or man-made shade over/outside storage structures.• Properly installed soffit vents or roof vents can help disperse or move heat.
Prevent Temperature Stratification	<ul style="list-style-type: none">• Use active measures to prevent heat stratification of temperature, including fans.

Active Cooling

Active cooling requires power for part of or all of the day, and whatever active cooling device is used must be adequate to accommodate the storage space. Choosing which type of active cooling system, and how many/the size of the unit(s) required will depend on a number of factors, among them the size of the space, the external ambient temperature and the ideal temperature range.

Some storage facilities will have properly installed or adequate temperature controls in place already, and active cooling can be achieved directly through a central control mechanism. In other instances, humanitarian organisations may need to install their own active cooling devices. Prior to installation of any unit, consult with a qualified installer so that they might understand both the size and the temperature requirements.

Monobloc Air Conditioners

Self-contained air-conditioning units – monobloc are single units that put out cool air from one side, but radiate heat from the other. Monobloc conditioners may not be suitable for smaller cold rooms built inside of a larger warehouse space, as all heat waste would be discharged into the open warehouse.



Split Air Conditioners

Split air conditioners have two components that are separated, but connected by a long tube of freon coolant, and usually have a single power source. The advantage of split air conditioners is that the heat output can be placed outside meaning it can be larger, noisier, and won't impact indoor ambient temperatures.



Freezer Units

Freezer units are used for rooms that need to be near or below freezing temperatures. Freezer units are typically very large and need to be mounted on the roof of the storage area to maximise the flow of cold air.



In actively cooled spaces, there are some special considerations:

- **Floor insulation** - Sometimes freezer rooms have insulated flooring as well. Insulated floors will help keep energy costs down as less heat is absorbed from the ground. Additionally, cold rooms can cause something called “frostheave” in which water in the ground under the storage site is frozen, causing the ground to shift and crack.
- **Heat output** – Regardless of the method, any form of active cooling will have some form of heat output. Spaces should be designed with heat being expelled outdoors wherever possible. Exhaust heat should also not endanger the health of workers or cause potential fire hazards.
- **Energy needs** – Active cooling always requires some form of power. Usually even medium sized spaces require more power than a solar electric system can provide.
- **Duration** – Not all active cooling systems need to be powered or cool the air at all times. The needs for part time cooling depend on the insulation value of the structure, the outside temperatures, the time of year, and the types of medicines stored. Before installing a system that will only have access to intermittent power, a proper heat mapping exercise should be conducted, and an assessment of the medical items should be finalised.
- **Condensation** – In the process of air conditioning, when hot air gets cooled as it passes through the evaporator coil - often in the indoor part of the refrigeration system - water condensation occurs, and water needs to be collected and exhausted in a controlled manner.
- **Uneven distribution of cooled air** - Depending on the refrigeration system, the load configuration and the chamber design and its performance, the air temperature is distributed unevenly and deviations from the Set Point in some spots may be larger than expected, putting at risk the stability of the goods stored/transported in it.

Note: active heating may be required in some instances. In storage areas that are prone to extreme cold, or when operating in climates with extreme cold, active heating may also be required in order to maintain the manufacturer specified temperature ranges. Many temperature control devices – such as air conditioners – also have heating functions built in. The important thing for active heating is that temperature ranges also do not exceed the required temperature ranges.

Renting Commercial or Third Party Managed Medical Storage

Whether humanitarian organisations are planning on moving relatively small quantities of health commodities, or maintain a large, dedicated health supply chains, they should consider using the commercial market wherever available.

Properly qualified commercial service providers have many advantages:

- They likely already have access to expensive or specialised equipment used for properly maintaining pharmaceuticals and other health items.
- They will have an understanding of the prevailing regulatory requirements for managing health items in the local context and should have proper certifications/authorisations to do so.
- Will have access to specially trained staff.

Prior to engaging with or renting a privately managed medical storage facility, there are some things that humanitarian organisations may want to consider.

- When submitting a request for quotation for potential service providers, humanitarian agencies should:
 - Outline the types of commodities that will be stored in as much detail as possible. This will enable storage providers to more easily identify areas in which they may or may not have capacity to support the overall needs of the agency.
 - Ask if private companies have the required national certifications to store health commodities / ask to see copies of registration/certification where required. This may include special authorisation to store controlled substances.
- Agencies should consider the total scope of needs required. Do they require:
 - Reconditioning of passive cold chain boxes?
 - Pick and pack / kitting?
 - Re-palletisation/ Labelling?
 - Specialised inventory or reporting?
- Does the company provide disposal services for expired medical items?

Self-Managed Medical Storage

Humanitarian organisations are frequently faced with having to develop and manage their own storage facilities, often in locations with limited access to improved infrastructure. When identifying a self-managed storage facility, there are a few things to consider:

Stand Alone Medical Storage Locations

In addition to [the traditional factors surrounding the selection of regular storage locations](#), medical storage locations may have additional or extra considerations. Medical facilities that require some form of temperature control benefit from:

- **Proximity to health facilities** – the closer medical storage locations are to the final

distribution points, the less complicated the process transporting temperature-controlled items are.

- **Proximity to manufacture or central medical stores** – Upstream or distribution warehouses may want to be closer to facilities that produce medical items, or to national authorities that may supply or distribute medical items themselves.
- **Persistent electricity** – storage locations requiring temperature control that have access to regular and consistent grid power and have access to backup generators run a much lower risk of damage to stored items from gaps in power.
- **Shading** – The availability of partial or full shade over a storage facility can greatly reduce temperature fluctuations and reduce demand for electricity.
- **Controlled access areas** - The availability of locked cages, locked rooms or locked storage cabinets for high value and controlled substances can reduce risks of theft and ensure compliance with legal requirements.

Medical Storage Rooms in Mixed-Use Warehouses

In the absence of dedicated temperature-controlled storage spaces, humanitarian agencies can construct or utilise pre-existing self-contained temperature-controlled spaces inside of pre-existing storage facilities. Self-contained temperature-controlled spaces in larger warehouse structures have the advantages of:

- Being able to be scaled or right sized to the required volumes of climate controlled cargo items.
- Being able to co-locate non temperature-controlled items in the same storage facilities.
- The ability to build multi-chamber storage rooms to accommodate different temperature ranges.

Special temperature-controlled rooms constructed within the main building of a warehouse must still be appropriately insulated and must have some form of active temperature control to maintain the required range. National regulations may require a certified pharmacist among staff as mandatory precondition to manage pharmaceuticals.

Temperature Monitoring of Storage Locations

Temperature Mapping

Temperature mapping is the process of identifying and marking temperature zones inside of a warehouse used for storage of temperature sensitive commodities, including all anticipated temperature ranges required for storage. Whether or not humanitarian agencies are utilising an outsourced storage facility, or they are managing their own facilities, it is advisable to conduct a temperature mapping exercise so that warehouse managers can best utilise the available space. For more information on evaluating commercial climate-controlled space, reference WHO's guide on the [qualification of temperature-controlled storage areas](#). For more information on conducting temperature mapping on self-managed spaces, please reference WHO's guide on [temperature mapping of storage areas](#).

An ideal temperature mapping exercise utilises automatic temperature loggers, however humanitarian organisations might utilise handheld devices such as digital thermometers, or even traditional thermometers. There are several things to consider when conducting a mapping exercise.

Ensure that when the mapping exercise is conducted the warehouse is in same condition as it will ultimately be used to store items as:

- If the warehouse is meant to use air conditioning or other cooling solutions, ensure all temperature controls are enabled and running at the time of the mapping exercise. Note: agencies may wish to map the temperature of the facility without power as well to understand what conditions may be faced in case of a catastrophic power outage
- If the warehouse relies on passive cooling, ensure that conditions match the planned storage conditions, including all shading in place and all doors and windows are closed.

For small storage spaces (single rooms with low ceiling):

- Take a temperature reading at each of the four corners of the storage space.
- If the rooms are longer than four meters, then take a temperature reading along the edges of the floor and ceiling, with readings conducted once every two meters.

For large storage spaces, or locations with high ceilings:

- Take a temperature reading at every two- or three-meter interval both horizontally and vertically. Readings may not necessarily be conducted against a wall or surface – imagine the storage space is filled with invisible cubes of two to three meters in width stacked neatly on top of each other – temperature readings would be conducted at the corners of where each of these cubes intersect.
- If there are wide open areas where no cargo will be stored, it may not be necessary to take a reading – focus on known storage areas such as elevated racking, shelving, and packing/condition areas.

For all storage locations:

- Temperature readings should be recorded into a report or table.
- Temperature readings should be taken at multiple times a day, including in the morning, afternoon and nighttime. Ideally, temperature mapping should also occur during different times of the year, however this may not be possible for a number of practical reasons.
- If there are extreme temperature fluctuations throughout seasons, mapping should be conducted at different times of the year corresponding to seasonal changes.

The outcomes of a mapping exercise will inform how cargo is stored. If there are known areas with significant temperature spikes:

- Managers can be instructed to not store sensitive items in specific areas of the facility.
- Managers can identify potential airflow issues that may be the cause of temperature variations, such as placement of doors.
- Agencies can invest in infrastructure upgrades, such as improved powered cooling equipment or passive cooling techniques such as insulation or shading.
- Planners may choose to simply find another storage facility that is more appropriate for their needs.

Temperature Monitoring

Temperature monitoring is the process of continually monitoring temperature inside of a warehouse or storage facility using some form of recording device. Temperature monitoring can be both automatic, and manual.

All storage locations used to store time temperature sensitive temperature-controlled health commodities – whether they are freezer rooms, cold rooms or regular temperature regulated storages – should have some form continual monitoring of temperature. If there are

specialised packing and loading spaces that are dedicated to health items, they should be monitored as well. In high capacity warehouses this can be an alarm based automatic notification when temperature deviates outside of the set range. More likely in a humanitarian environment it will either be tracked with a wall mounted thermometer or handheld thermometer with daily checks. It is recommended that daily checks are taken at different times to identify possible temperature diversions at different times of the day.

It is important to note that temperature monitoring devices (including thermometers, freeze indicators, temperature recorders, alarm systems, event loggers and remote communication devices for monitoring temperatures at all levels of the cold chain) are internationally regulated by WHO PQS. Any use of electronic or automatic temperature monitoring should be done in line manufacturer specifications, including calibration, installation and routine use. Consult the manufacturer and/or qualified installer for more information before attempting to install or calibrate devices without professional support.

Automatic Monitoring

Automated temperature monitoring solutions are considered ideal for storage of temperature sensitive health commodities and should be utilised wherever possible.

Temperature loggers

A temperature logger is a standalone device that continuously records temperature on an ongoing basis. Loggers are frequently used while shipping temperature-controlled items, however they may be used to record temperature in remote locations or locations with poor infrastructure.

Temperature loggers come in multiple varieties, including those that require persistent connection to external power, and those that can run off battery power for extended periods of time. Battery powered loggers might work for makeshift storage locations in remote areas, however most loggers require data to be downloaded in a proprietary format. This means that on a regular basis or prior to dispatch of the item, the temperature logger would need to be read to ensure no deviation in temperature has occurred. Some temperature loggers are single use, and others are multiple use.

Additionally new technology for temperature loggers is always under development. Temperature logger stickers are being used by many humanitarian agencies, readable by mobile phones, with cloud-stored datalogger information.

Active Monitoring Devices

Active monitoring devices are specialised equipment that both continually record temperatures and transmit temperature status in real time. Active temperature monitors are ideal in scenarios where temperature regulated items are stored in closed rooms that aren't accessed all the time, or when more than one temperature control facility is in use, but active monitoring devices can be used in any warehouse where temperature monitoring is required.

Active monitors come in a variety of formats, and the way they provide data come in a variety of interfaces. It is advisable that humanitarian agencies interested in using active monitoring devices find devices that:

- Can work both with and without external power (in case of power failure).
 - Have the ability to provide alerts when predefined temperature ranges are met.
 - Don't require fees or subscriptions for using software associated with the devices.
-

In an ideal setting, active monitor devices should be placed throughout the entire warehouse facility. The [WHO Expert Committee on Specifications for Pharmaceutical Preparations](#) suggests that electronic temperature monitors “should be arranged in a grid fashion along the width and length of the area so that the area is reasonably covered, [...] located every 5–10 meters.” However, many humanitarian operations function in less than ideal conditions, and the [WHO guide on Maintenance of storage facilities](#) indicates correct the correct locations are established in case of limited resources:

- Ambient and controlled ambient storage areas: Position sensors in the places where seasonal hot and cold spots have been observed during the mapping studies.
- Freezer rooms and cold rooms: Position sensors in the places where operational hot and cold spots have been observed during the qualification and/or mapping studies.

The overall layout and number of electronic monitoring devices will depend on the size of the space, and on the resources available to the humanitarian agency. General rules to consider:

Condition	Ceiling less than 3.5 meters high	Ceiling greater than 3.5 meters high
Limited number of monitors	Place monitors near the highest part of the wall, approximately 0.5 meters from the ceiling. Repeat at 5-10 meter horizontal intervals.	Place one monitor near the highest part of the wall, approximately 0.5 meters from the ceiling, and then another sensor near the midpoint of the wall, at Repeat at 5-10 meter horizontal intervals.
Capacity for multiple sensors	Place one monitor approximately 0.5 meters from the ceiling, and then another at 1.2-1.5 meters from the ground. Repeat at 5-10 meter horizontal intervals.	Place one monitor starting at 1.2-1.5 meters from the ground and add additional sensors every 2 meters up the wall until reaching approximately 0.5 meters from the ceiling. Repeat at 5-10 meter horizontal intervals.
Storage facilities with extreme temperature ranges	Consider placing monitors starting at 0.2 meters from the floor if extreme temperature changes are expected.	

Installation of automatic temperature monitors should take into account alcoves or irregular warehouse shapes. If more monitors are required because of lack of airflow or increased ambient heat in some areas of the facility, consider placing available monitors in those locations over wide-open areas with consistent temperature ranges.

Whatever active monitoring devices are used, ensure that:

- Humanitarian personnel using the devices are fully training in using and reading the equipment.
- The devices are in good working order, and if possible, covered under a warranty.
- Installed by knowledgeable persons. If no person working for the humanitarian organisation is capable of managing the install, utilise an outside service such as the warehouse provider or a private company.
- There is a plan to check on and service the devices at a period defined by the manufacturer.
- The automatic monitoring systems should provide a readout via software or website that is easy to understand, and ideally in a language spoken in the local context.

The below arrows indicate the potential locations for temperature monitoring devices.

Temperature monitors in warehouse with elevated storage:

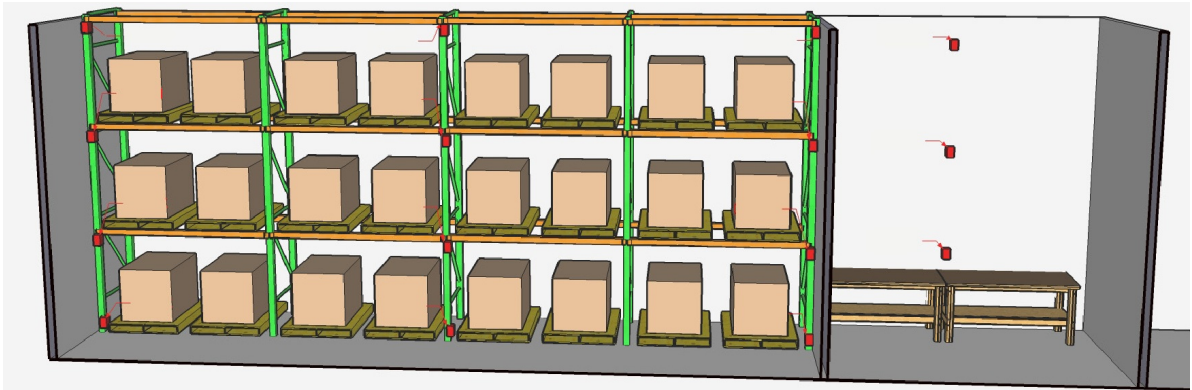

Temperature monitors in walk-in cold storage room:

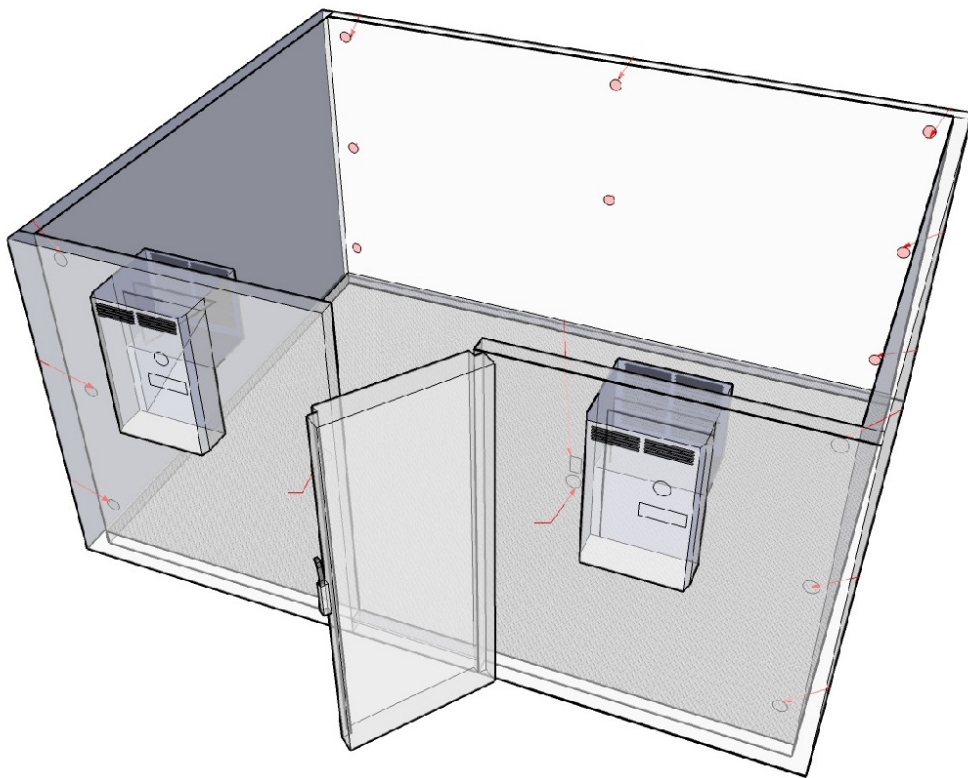

Source: [WHO - Temperature mapping of storage areas](#)

Manual Monitoring

Manual temperature monitoring of health commodity storage spaces has been practiced for years and was prevalent in most locations until automated monitoring systems became more widely available. Even with advanced monitoring systems, manual monitoring is still used in many humanitarian settings, especially in rural areas, or in areas with heavily impacted infrastructure.

The concepts behind manual monitoring are not dissimilar to those of the automated monitoring systems:

- Self-powered digital, non-digital, or non-powered thermometers can be hung at intervals throughout a climate-controlled storage space and will need to be checked on an ongoing basis.
- Electronic handheld temperature readers can be used to manually check temperature readings in storage locations. This involves holding the manual temperature reader in different locations of the storage facility and recording the temperature at regular time intervals.

Manual temperature monitoring routines are better suited for smaller storage facilities equal to a single room or a small storage site. Attempting to manually track temperatures in large warehouses, or storage facilities with ceilings taller than 3.5 meters may not be feasible.

To facilitate manual monitoring, storekeepers should set a routine, ideally checking two times a day. To make things easier, if there is more than one thermometer in the storage facility, the storekeeper should record the highest temperature found in the room – trying to maintain records on every thermometer may be difficult and confusing. At a minimum each separate space – such as room or dedicated area of the warehouse - should have its own manual monitoring chart. Ideally, in large warehouse rooms multiple manual monitoring charts should be used, particularly if using multiple different active cooling systems, or where one side of the room is more exposed to possible deviations in temperature, such as an open loading door.

Below is an example manual monitoring chart:

Cold room/refrigerator number:
Start date: <dd/mm/yyyy>
Key: FI = freeze indicator (status OK or X)

Equipment model:
Location:

Day	1	2	3	4	5	6	7	8	9	10	11	12	13	14	15	16	17	18	19	20	21	22	23	24	25	26	27	28	29		
Temperature chart	°C																														
	+16																														
	+15																														
	+14																														
	+13																														
	+12																														
	+11																														
	+10																														
	+9																														
	+8																														
	+7																														
	+6																														
	+5																														
	+4																														
	+3																														
	+2																														
	+1																														
0																															
-1																															
-2																															
-3																															
-4																															
-5																															
FI (X or OK)																															
>=8 °C alarm		Once every 24 hours, enter high alarm status and maximum temperature recorded by the continuous temperature monitoring device																													
Alarm time or OK																															
Maximum °C																															
<= -0.5 °C alarm		Once every 24 hours, enter low alarm status and minimum temperature recorded by the continuous temperature monitoring device																													
Alarm time or OK																															
Min °C																															
Initials:																															

Province:
 District:
 Health centre:

Month:
 Year:
 Supervisor:

Remarks:

Taken from: [Immunizationacademy.com](http://immunizationacademy.com)

Once each monitoring chart has been completely filled, it should be backed up in a binder and stored in a safe location – this will enable planners and managers to look at historical trends and identify potential problems with individual storage facilities.

Title

Download - Template Temperature Monitoring Chart

File



Cold Rooms and Freezer Rooms

Cold rooms and freezers rooms are typically custom built and meant to store cargo items that occupy traditionally low temperatures. This includes products below freezing temperatures, as well health items that occupy the +2°C to +8°C range. Rooms with cold storage or freezer capacity typically are custom built for the storage requirement, and are subject to higher degrees of control, such as continuous monitoring capacity or redundant power systems. Cold and freezer rooms also require specialised equipment and insulation.

In the majority of operations, items requiring storage below +8°C usually make up a small portion of the overall volume of cargo items, and properly calibrated cold storage rooms often don't need to be large, and ideally should only match the actual known requirements. In many cases, a standalone electric refrigerator/freezer will meet the storage requirements for most agencies. Cold storage rooms can represent a substantial financial investment and given the duration of both emergencies and available funding, such rooms are typically only planned when either the volume of the incoming cold storage items are substantial, or when the duration of project is known to be long.

Walk-in cold room:

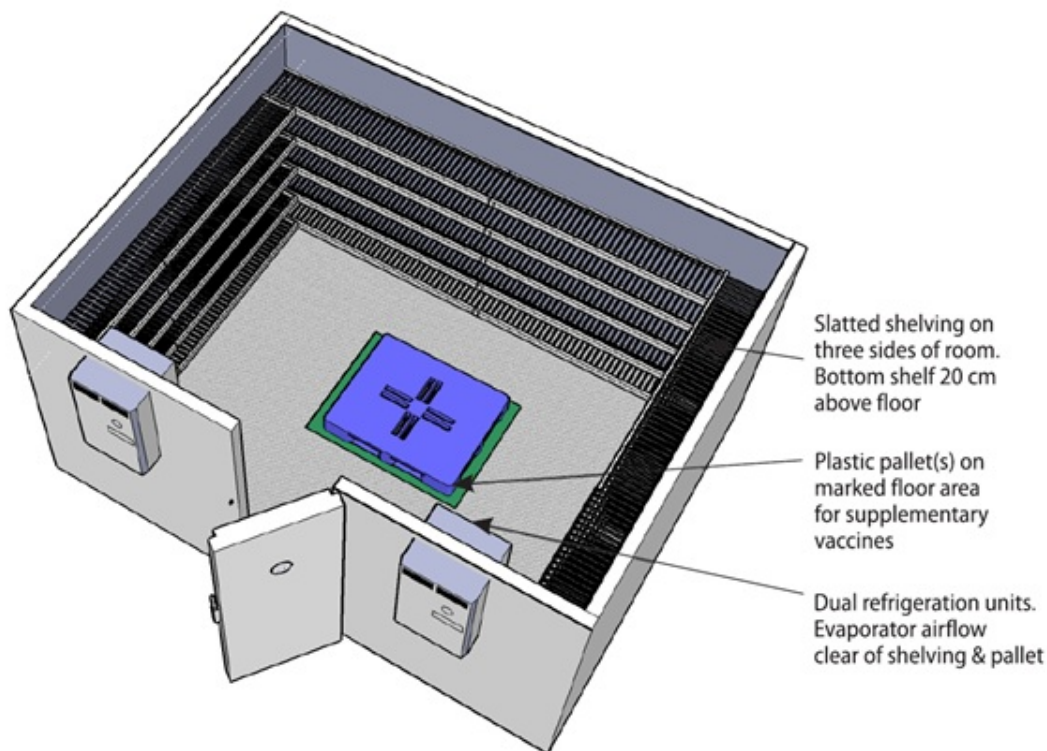

In instances where humanitarian agencies require large, or even warehouse sized refrigerated storage, it is strongly suggested that agencies speak with a licensed professional or attempt to outsource the storage space to a third party commercial provider. Large scale refrigerated storage or refrigerated warehouse spaces are fairly common amongst large manufacturers, or amongst national authorities, and their overall functioning is not dissimilar to smaller refrigerated storage spaces, however the costs and complexities associated with constructing and maintaining these facilities should only be overseen by experienced professionals.

In addition to industrial scale refrigeration, other features of refrigerated warehouses might include:

- A kitting or packing area – an area used to assemble pallets or kits that is also contained within a refrigerated space.
- Specialised doors/loading bays – doors and loading bays will have proper insulation, plastic flaps, or even specially designed fans to prevent heat loss through openings to the external world.

Temperature-controlled pallet standing storage area:

Pallet standing store

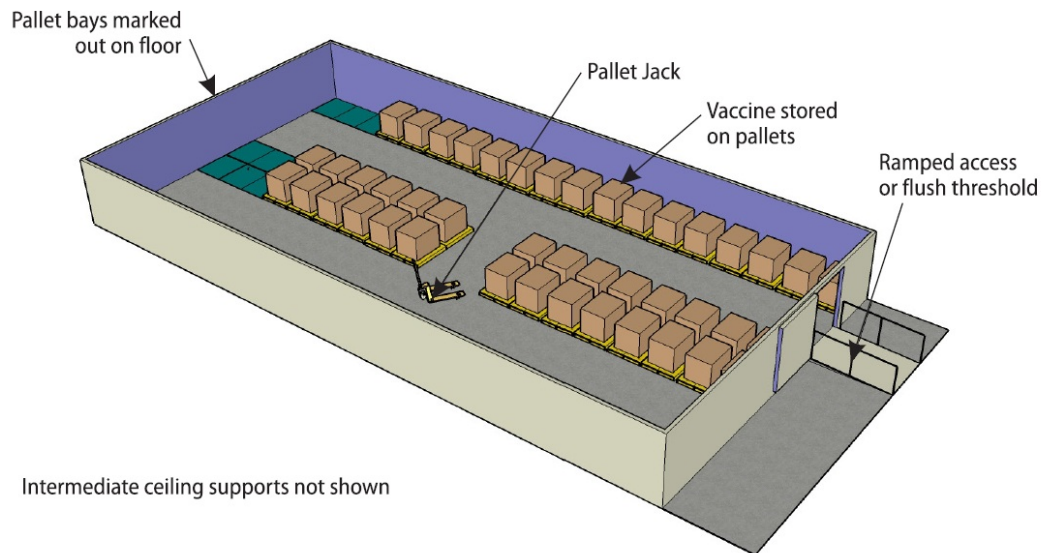

Temperature-controlled elevated racking storage with kitting/order assembly:

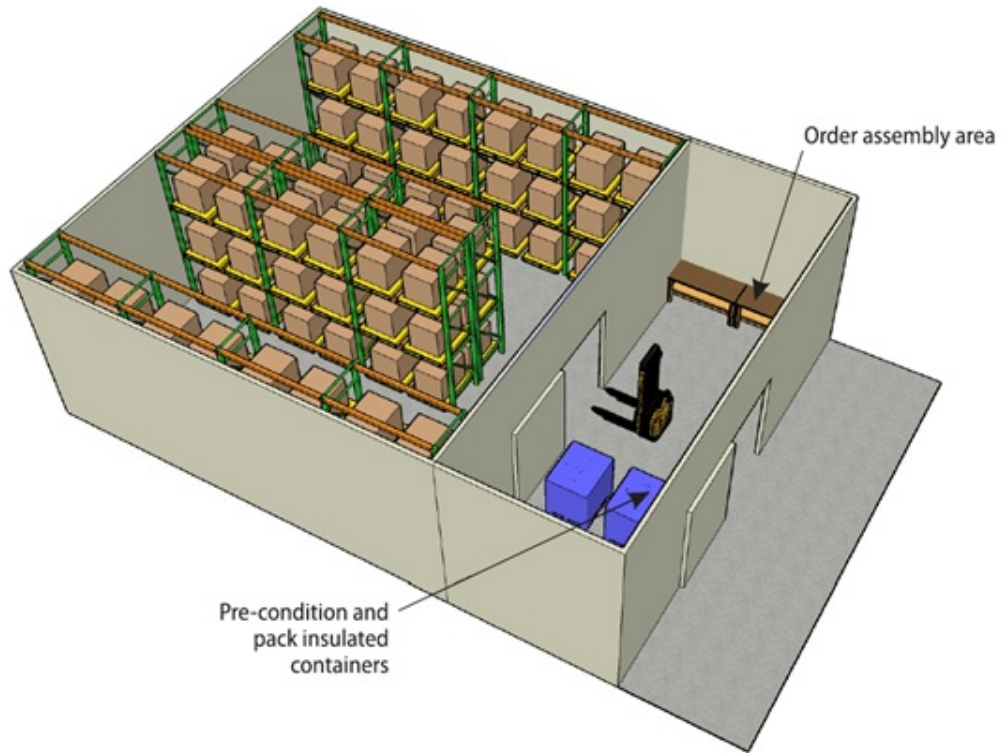

Temperature-controlled dock seal:

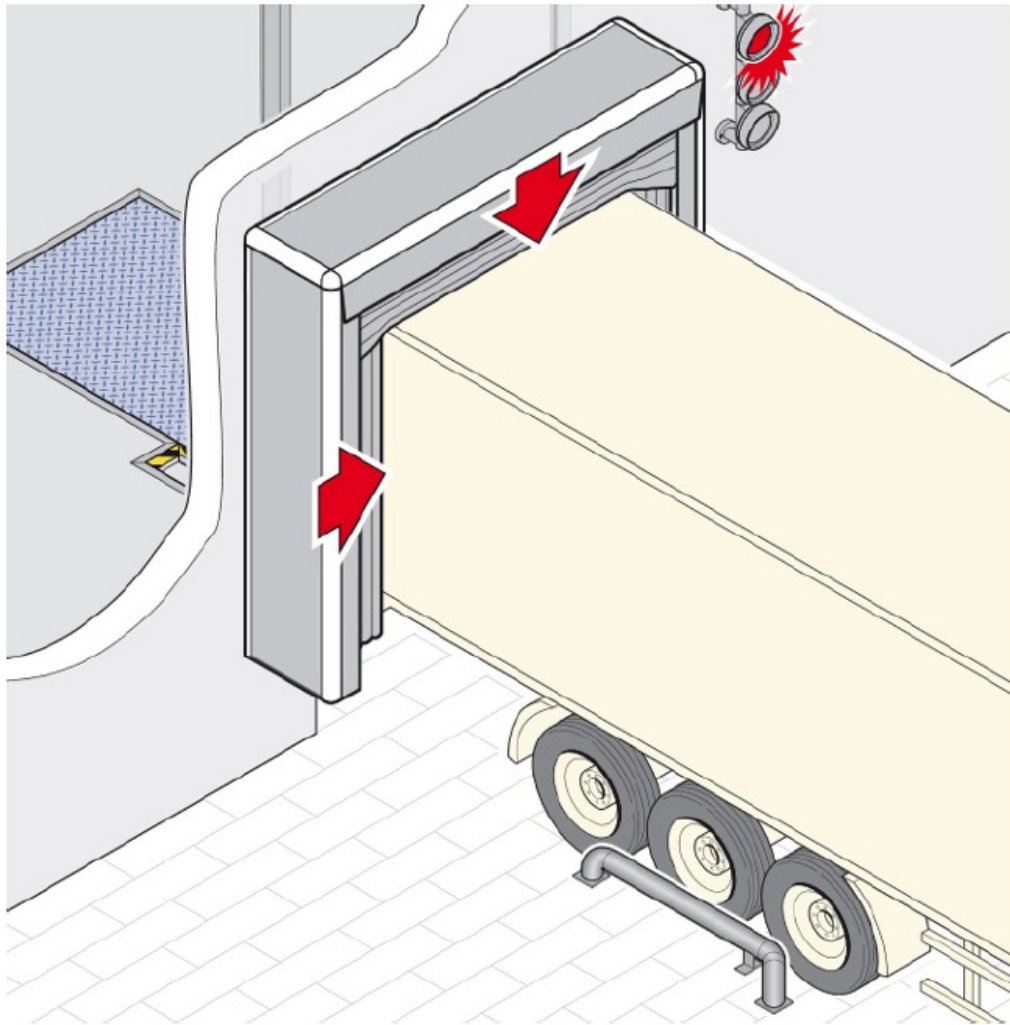

Taken from: [WHO - Design and procurement of storage facilities](#)

Stand Alone Refrigerators and Freezers

Some health commodities and some humanitarian health related storage needs may only require the usage of stand-alone freezers or refrigerators. Refrigerators and freezers tend to be useful for vaccines and other small volume pharmaceutical items, as the capacity of refrigerators is relatively small. However, refrigerators and freezers are good alternatives when the known quantities of stored items will be low volume, or when no other alternatives are available. Additionally, standalone refrigerator and freezers may be required for ice and cool packs if reconditioning of passive cold chain boxes is required.

Much like air conditioners, refrigerators and freezers also produce heat exhaust. If refrigerators/freezers are kept inside of a warehouse facility, there should be proper ventilation to avoid excessive heat built up, and planners should be aware of the impact increased temperatures might have on other collocated stocks. In instances where multiple freezers and/or refrigerators are in the same storage location, this may become a problem requiring dedicated attention.

Configurations for Refrigerators and Freezers

Though only basic equipment may be available in many field contexts, there are still special configurations that humanitarian organisations maintaining cold chain medical items may wish to consider.

Medical Grade Refrigerators/Freezers – There are a variety of medical grade freezers and refrigerators that are purpose built for maintaining keep cool and frozen grade medical items. Medical grade refrigerators and freezers are internationally regulated by WHO prequalification. Some characteristics of these refrigerator/freezer units might include:

- Highly calibrated thermostats/cooling units.
- Clearly defined set points.
- Back up battery systems in case of power failures.
- Alarm systems in case of temperature excursions.
- Clear windows to make identifying contents easier without having to open doors.

Specialty freezers and refrigerators are often also right-size, designed to only accommodate the anticipated demand of those specific temperature ranges, meaning they can be purchased in relatively small sizes, and different temperature requirements can be stored in different units.



Wherever possible, humanitarian organisations should avoid regular consumer grade refrigerators and freezers for any health items that have highly specific temperature ranges, or for health items that can be easily damaged by excursions. For example, vaccines tend to have a very low threshold for temperatures above/below defined ranges, and without clearly defined set points or precise monitoring a regular consumer grade freezer may not be sufficient.

If agencies plan on using regular consumer grade freezers or refrigerators, they will want to thoroughly assess the capacity of the units, including:

- Logging temperatures inside the for 5-7 days *prior* to storing temperature-controlled items to ensure that temperatures remain consistent and within the anticipated ranges. Monitoring should be done the same as a temperature-controlled warehouse –

temperatures logged once every few hours.

- If possible, agencies should use temperature loggers inside refrigerators/freezers to map any temperature excursions for functions.
- Install a universal power supply (UPS) with an alarm system in case of power outage.

Top Loading Refrigerators/Freezers – A common method for conserving power/preventing heat loss is the use of top-loading refrigerators and freezers. Top-loading units open from the top instead of the side – as cool air sinks downward, there is less of a chance of cold air escaping, maximising energy for the refrigerator or freezer. Much like consumer grade units, there are also medical grade top-loaded refrigerators and freezers that should be considered when procuring.



Persistent Power

Refrigerators and freezers require access to consistent power, especially when storing vaccines. Due to the fact that persistent power isn't always available in all field locations where humanitarian actors may be operating, there are a variety of power options that should be considered.

Compression Refrigerators: Plug-in Power – Basic refrigerators and freezers will come in plug-in models only, not dissimilar to those used in home settings. Some freezers and refrigerators specifically designed for management of vaccines and other medical commodities may come with built-in battery backup systems that enable the units to continue to maintain active cooling for periods of intermittent power outage. Built-in power backups generally won't provide power longer than a few hours, and users should consult manufacturer guidelines and compare against anticipated power outages in the areas of storage.

Absorption Refrigerators: Kerosene/Gas Powered – Completely off-grid refrigerators and

freezers traditionally have been powered with Kerosene and other forms of combustible gas. Gas powered refrigerators/freezers are typically powered using compressed gas cylinders or liquid gases – the gases are used to ignite a pilot light that heats permanently sealed coil that is chemically designed to produce a cooling effect. Gas powered refrigerators – though widely used – have slowly become less common due to the health risks and fire hazards associated with their use. Additionally, gas powered freezers/refrigerators will still require a supply of fuel, any disruption of which will cause the units to stop working. Depending on the size of the gas cylinder or the refrigerator units, gas powered refrigerators/freezers may need to be monitored and changed frequently.



Solar Powered – As costs of batteries and solar panels have gone down, the use of solar powered refrigerator units has increased in many remote areas. The basics of using solar power for refrigeration are no different than the basics of using solar for any other electrical appliance. For more information, please reference the sections on [solar powered systems](#) and [battery backup systems](#). The important things to note when using solar and battery systems for refrigerators and freezers is that refrigerators/freezers rely on electricity, and that the power is sufficient to match the consumption needs of the units – freezers and refrigerators tend to use a large amount of electricity, especially in warm climates.

In many cases, humanitarian organisations may wish to install solar panels and/or batteries specifically for standalone freezers/refrigerators; many manufacturers produce self-contained solar powered freezers and refrigerators that humanitarian organisations may buy. When investigating solar powered or battery backup supported freezers/refrigerators, it's important to note the difference between "Solar direct" power and "solar battery power".

- Solar Direct Power – the refrigerator/freezer is linked directly to the solar panel without any intermediary battery, meaning there is no electricity produced while the sun is not directly shining on the panels. Refrigerators/freezers that don't have built in battery backups will experience power outages during the nighttime.
- Solar Battery Power – Solar battery powered freezers/refrigerators have a regulated battery system in between unit and the solar panels, allowing the batteries to absorb power through the day and slowly disperse it through the night. A properly designed

battery backup system will accommodate the full need of the refrigerator/freezer, without any breakages in power, even during emergencies. A battery backup system should still have [sufficient safety controls](#), like any battery system in use.

Solar Battery Powered Refrigerator

Solar Direct Refrigerator

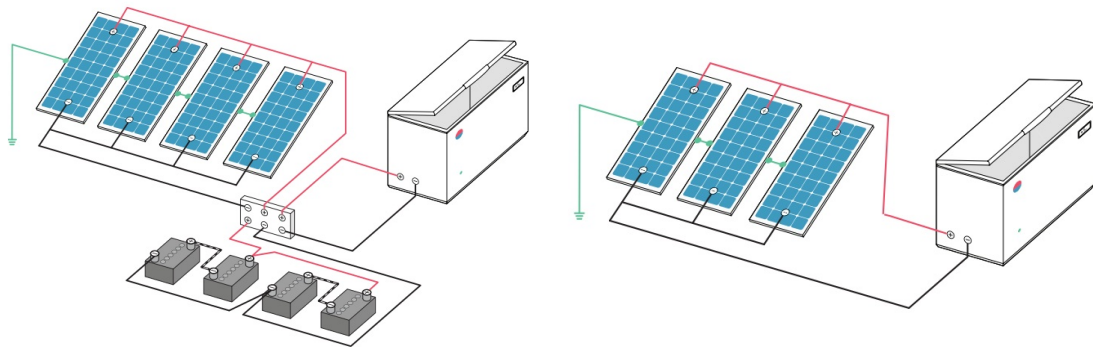

Taken from: [WHO - Solar direct-drive vaccine refrigerators and freezers](#)

In the event of persistent power outages/power shortages with no alternative provided for backup power, protocols should be put in place to ensure that goods stored within refrigerators and freezers maintain internal temperature during outages. This might include:

- Instructing staff to not opening the units while power is out.
- The use of temperature dataloggers.
- Using ice and cool packs to augment temperature controls.

Maintaining freezers and refrigerators

Refrigerators and freezers will degrade over time. Signs of degradation might include:

- Condensation or ice forming on the outside of the refrigerators.
- The compressor motor used to generate cooling runs for noticeably long or frequent periods of time.
- The interior of units never become cool, or reach a given set point.

Suggested maintenance procedures for medical grade refrigerators and freezers include:

- Keep units clean by regularly washing with mild soapy water solution.
- Keep door seals clean, avoiding build-up of material between folds and at corners.
- Remove build-up of ice (use the defrost system or a blunt scraper).
- Keep drains free of debris.
- Clean condenser coil (fins), ensure fins and cooling fan and any grilles are free of dust, fluff and debris.

Physical Management of Health Supplies

The storage and physical management of health items should follow most of the standard basic principles of [warehouse](#) and inventory management. In addition to basic standards, there are a few additional factors to consider when storing health items.

Organising Health Items

The arrangement of health items in a warehouse or a storage room can take multiple forms. In large scale warehouses, or warehouses where cargo items are palletized, traditional methods for arranging cargo will usually be sufficient, provided that temperature, humidity and light exposure requirements are met.

In many cases however, health items are stored loose, or broken down into much smaller accounting units. Due to the relatively small volumes of health items, and to the relatively high number of individual line items, health items are frequently stored on shelves, segregated by individual units. Segregating by individual units also makes it easier to distribute relatively smaller quantities of items that may only be consumed in smaller proportions.

“VEN” Storage

In medium to large sized storage facilities and storerooms used to store medical items, health items can be segregated by the risks associated with being exposed to temperature fluctuations, by the frequency or importance of use, and by the control requirements in place. “VEN” storage is defined as prioritizing storage locations for items based on if they are defined as:

- Vital (V)
- Essential (E)
- Nonessential (N)

Similar to the [zonal strategy of segregating items based on their weight and overall frequency of usage](#), the VEN method helps identify the physical location in a warehouse where cargo items should go by placing cargo in categories that should be co-located together in storage locations. VEN storage analysis will help design the layout of storage facilities, identifying:

- Where the most temperature sensitive cargo should be located.
- Where specialty items, such as narcotics, psychotropics, or other heavily regulated items should be located.
- Where frequently used items should be located.
- Where extremely fragile items should be located.

Product Characteristics

Another method of organising and storing medications and medical relief items is segregating items by product characteristics. Arbitrary segregation is useful for quickly identifying medical items and may be especially useful in warehouses with high numbers of SKUs. In some cases, more than one sorting method can be used at the same time, such as first segregation items based on characteristic (project) and then segregating those subcategories by another characteristic (alphabetical).

Dosage Form – One of the most frequent methods of organising stock on racks and shelves is segregating items along the physical characteristics of their dosage form. Dosage forms might include:

- Pills
- Injectables
- Liquid consumables (Example: syrups)
- Topical (Example: creams)

The advantage of segregating by dosage form is that frequently similar dosage forms will have similar handling requirements. As an example, injectables frequently come in glass vials that should be handled as fragile items.

Alphabetical – In environments in which warehouse employees may not have special knowledge of health items, segregating and storing items alphabetically based on their generic names will enable rapid identification of storage locations. Alphabetical storage only works best in storerooms with:

- Limited or no difference in temperature controls for different items in stock.
- Smaller storerooms without large variables in temperature or large volumes of SKUs.
- Storage environments where there is a commonly understood primary language.

Frequency – [Much like zonal storage plans for bulk cargo](#), some planners may want to arrange stock items in a warehouse based on their frequency of use. This would include placing the most frequently used items on shelves or racks closer to doors, and near the front of storage rooms.

Pre-defined Coding – Humanitarian organisations responding to any health emergency may have a variety of methods and reasons for defining their own coding systems. These coding types might include:

- Project or donor – segregating items based on the project for which they were purchased, and for which they must be used.
- Regulation – some local or national authorities might have their own commodity coding system based on prevailing health regulations.
- Inventory Management Systems – If humanitarian organisations already have their own inventory management systems that can assign categorization to many things, including health items.

Secure Storage Areas

Wherever pharmaceuticals are stored and transported, there may be specialty “controlled substances” that require secure storage. Items requiring secure storage might include:

- Items of high value.
- Items that have a high risk of addiction or substance abuse.
- Items that are specifically regulated under local or national laws.

As a general rule, any item that is classified as a narcotic, a psychotropic, or some other form of analgesics drug should be placed in secure storage, with two-step access as preferred option. In many cases National Essential Medicines Lists will outline any drugs that require secure storage under national laws. In some cases, humanitarian organisations may be completely banned from storing certain items.

	Narcotics: <i>morphine, opium preparations, pethidine, diamorphine, papaveretum, hydrocodone and oxycodone, dipipanone, and tramadol.</i>
Examples of Common Controlled Substances:	Other opioid and strong analgesics: <i>pentazocine, codeine, dihydrocodeine, dextropropoxyphene, dextromoramide, and buprenorphine.</i>
	Psychotropic drugs: <i>usually the group of drugs called "benzodiazepines," the more common being diazepam, temazepam, nitrazepam, flunitrazepam, and oxazepam. Clonazepam, used to treat epilepsy, may be found under a different class, and is not always under the same control. Strong tranquilizing medicines, such as chlorpromazine, may also be found under this heading.</i>

Taken from: JSI Deliver [Guidelines for the Storage of Essential Medicines](#)

Any item requiring secured storage must be safely and adequately stored in an appropriate location. Depending on the volumes of the controlled substances and the available space in the storage facilities, secure storage might include:

- A room with lockable doors.
- Locking caged shelving or racking.
- A locking safe, securely attached to a permanent surface.

The advantage of a separated room with lockable doors is that it may be regulated to its own temperature when required for the commodity items. In many cases however, controlled substances must be kept in the same open general space as the rest of the commodities in the warehouse. Where controlled substances are kept in the same location as general cargo, organisations may use caged shelving or racking:



Caged racks/shelves should be lockable and should be sturdy enough to avoid being broken into easily.

General rules for maintaining a secure storage location include:

- Keys should only be assigned to authorized personnel. Ideally, a responsible warehouse manager will control access to the warehouse, while only staff authorized to access the controlled substances storage location within the warehouse will hold keys to the lockable storage location. In some countries, the persons with access to keys to lockable items must undergo a licensing procedure.
- Stock card should be used in all scenarios, including a sign out sheet requiring personnel to sign as items are removed.
- Where available, an alarm system should be used.
- Where available, a camera system with recoding capacity should be installed, especially in scenarios where large volumes of controlled substances are stored.

Other Planned Spaces

In addition to other specific infrastructural requirements for warehousing and storing health commodities in a humanitarian context, logistics planners should also consider planned spaces for key activities.

Receiving/Dispatching – warehouses of sufficiently large sizes ideally should have special demarcated areas specifically for goods that have either just arrived or are being consolidated for dispatch. In many storage facilities, the loading/receiving areas are either right next to loading bays/doors, in an intermediary chamber, or even possibly outside the storage facility. When designing a loading/receiving area, planners must consider the need for temperature-controlled cargo and health items; much like temperature-controlled storage spaces, areas specially designated to for dispatching/receiving should also be temperature-controlled wherever possible. Additionally, dispatching areas may also have space specifically set aside for packing keep cool boxes if required by needs of the project.

Quarantine Area – see section “[Damaged and Expired Health Items](#)”.

Kitting Area – Kitting areas are common in humanitarian warehouses; however, kitting of health items may require special attention. Areas used to kit health items including pharmaceuticals and medical devices may require extra attention; areas used to kit health items should be thoroughly cleaned and may require temperature-controlled work areas to maintain proper conditions for the items. Kitting may take hours or even days depending on the work order, and the kitting area should be as appropriate for storage of health items as the main storage facility.

General Storage Guidelines for Medical Items

In any storage location where health items might be stored, there are several general rules that will help avoid loss to stock through damage or unanticipated expiration date.

Item Placement and Visibility:

- Avoid storing boxes, or exposed health items in places that receive direct sunlight. Even short periods of exposure to sunlight can damage some health items, especially those labelled as light sensitive.
- Unless there is an advanced inventory management system in place, [stock cards are strongly recommended](#). Stock cards should contain information on:
 - Batch numbers.
 - Expiration dates.
 - Temperature ranges.
 - Product codes.
 - Programmatic use.
- Avoid mixing the same medication from different batches/expiry dates – if your storage facility is warehousing the same health item but from different batches/expiry dates, those items should be kept separately, and recorded separately.

If storing health items in cartons:

- Ensure that cartons with arrows indicating which side should be facing upward are properly followed.
- Ensure cartons are properly labelled, with contents, expiration dates, batch, and other relevant information visible. If no labels are used, or the boxes come unmarked, write the relevant information on the side.
- Follow manufacturer's directions on stacking and handling.

It is always important to remember that the majority of health items are classified as fragile. Handling personnel and practices should be in place to ensure safe management of goods.

Any storage facility used to store health commodities protect all items from physical damage, moisture, excessive heat or cold, sunlight, dust, dirt, and pests. Cleanliness in a warehouse used to store medical items is of even more importance than it is for some other categories of commodities.

Colocation with Other Materials – Pharmaceuticals and medical support devices should always be stored separately from chemicals or food. Examples of chemicals commonly found in humanitarian contexts might include:

- Pesticides
- Fertilizers
- Cleaning agents

- Fuel
- Foodstuffs and bulk food items

However, even non typically hazardous materials – such as bags of cement – can impact health items, both in storage and in transport. Wherever possible, health related items should be stored in adequately prepared and separated spaces.

Shelving:

The use of shelving is very common when managing health items. Shelving is useful for easily storing small quantities of a large number of SKUs, enabling storekeepers to withdraw discrete quantities of items while still being able to neatly segregate and track them.

Frequently shelving is used in the same location as racking; racking is better suited for managing large cartons or pallets and may be used before the cartons are open and the line items are broken down into discrete inventory units, while shelving is better suited for managing individual units that are withdrawn on a case by case basis. Both have their use cases in health facilities.



In addition to the [normal practices of using shelves](#), there are some special considerations when using shelves to store health items:

- Place glass vials on the bottom shelf to minimise risks of damage from falling items.
- Place liquids on the bottom shelf to avoid damaging other items in case of a rupture or leakage.
- Ensure that all items are clearly visible, and when labelled, labels are legible.
- Even if the quantities are small, use stock cards to record transactions. Multiple stock cards can be kept in a single pouch or container to save space.
- In storage areas with temperature zones, temperature sensitive health items should be stored where temperatures are most appropriate for their manufacturer specified requirements, usually on the lower shelves.

Palletisation:

If health items are stored in pallets, there are some key rules for proper management beyond the regular guidelines for [managing pallets](#) and [ground stacking](#):

- All cartons containing health items should be clearly labelled with relevant information, and labels should be outward facing and visible.
- Medications are frequently light, and sub-packaging may have much empty space – cartons containing health items might be easily crushed or damaged and should not be stacked to excessive heights. Never exceed 2.5 meters as a maximum height of cartons stacked on a pallet, and ideally less height where possible.
- When storing pallets with multiple types of health items, pallets may need to be physically separated by a minimum of 30 centimetres to allow access to all sides of the pallet for inspection and handling purposes.
- Where possible, store like-items together, such as health items from the same batch and with the same expiration date. Intermixing different items will make picking specific items more difficult.
- The use of heat treated, or plastic pallets is recommended for storing health items wherever possible.

Damaged and Expired Health Items

Due to the sensitive nature of pharmaceuticals and other medical devices, it is extremely important that managers of health stores monitor, identify and isolate damaged or expired items for proper repair or disposal and prevent accidental release of such items into distribution to avoid harm to end user.

Managers of health items should always track the expiration dates of health items, and routinely conduct [inspections and physical inventory counts](#) to ensure any and all instances of expiration or damage are captured. The intervals required for inventory counts of health items may be more frequent than non-medical items, and managers may wish to conduct a physical inventory every three months or even once a month. Based on the number of individual line items in any medical store, a full physical inventory may be prohibitively complex, so managers may also wish to conduct random sampling on an ongoing basis, with intermittent physical inventories through the year.

Health items that have been identified as either damaged or expired should be removed from their regular location in the storage space, and isolated in a specially identified “quarantine area” within the storage facility. A quarantine area doesn’t mean that health items are infectious, but rather they are to be treated separately from the rest of the items on stock. Quarantine areas should be:

- Clearly marked and labelled as being stock that cannot be issued as regular stock.
- Clearly physically separated from main stock items. This might include painted areas on the floor, or possibly even separate rooms.
- Ideally, quarantine areas should be lockable, and keys should be kept with the warehouse manager.
- In some contexts, the isolation and management of damaged/expired health items might have specific regulations, including secure monitoring and time limitations. Logistics personnel should consider local laws prior to designing a quarantine strategy.

Items placed in quarantine should:

- Be tracked separately from non-impacted stock items, including their own stock cards and their own record in an electronic inventory system.
- Be prepped and ready for disposal.

- Any medication, be it expired or damaged should not be considered fit for human consumption and should be disposed of safely and in a manner in compliance with local regulations. Please reference the section on [medical waste management](#) for more information.

Inventory Management of Medical Items

The process for the proper management of health items should follow the general guidelines for [all inventory management](#), including overall [demand forecasting](#) and [inventory control mechanisms](#). There are – however – additional concepts that are special to managing health items.

First Expired/First Out (FEFO)

FEFO as a general rule is important for health products because it emphasises expiration dates of products, irrespective of when those items may have entered general storage. In FEFO, products are rotated out of storage based on how close they are to expiration. In health supply chains, there may be multiple products of the exact same type that happen to have different production/expiration dates; FEFO helps reduce product loss by ensuring that wherever possible, the shortest shelf-life items are used first.

In order for FEFO to be effective:

- Expiration dates should be clearly identifiable on products held on shelves and racks. If the expiration date cannot be easily seen on the carton or packaging, then the expiration date may be noted on stickers or pieces of paper on the outside of the cartons/pallets.
- Expiration dates should be recorded on all stock cards and warehouse ledgers/inventory systems.
- Similar items with different expiration dates should be separated by expiration dates. Where possible the items with the closest expiration dates should be moved to the front of racks or shelves, something that might be more useful in smaller storage facilities with loose items on shelving.
- Physical inventories should be conducted routinely, with an emphasis on identifying short shelf-life items that may have been ignored or intermixed with other stock items.
- Persons managing inventory should be told to issue short shelf-life items first wherever possible.
- Items approaching three to six months prior to expiration dates should be flagged. Any items with less than three months of shelf life should be communicated to project managers immediately so action can be taken as needed.

Product Inspection

The physical characteristics of health items may change over time and may be clear signs of degradation of product quality. In addition to looking for physical damage to packaging or tracking expiration dates, there are things that logistics managers of health products might look out for to determine if a product has quality problems:

All products	<ul style="list-style-type: none"> • Broken or ripped packaging (vials, bottles, boxes, etc.) • Missing, incomplete, or unreadable label(s)
Liquids	<ul style="list-style-type: none"> • Discolouration • Cloudiness • Sediment • Broken seal on bottle • Cracks in ampoule, bottle, or vial • Dampness or moisture in the packaging
Light-sensitive products (such as x-ray film)	<ul style="list-style-type: none"> • Torn or ripped packaging
Latex products	<ul style="list-style-type: none"> • Dry • Brittle • Cracked
Lubricated latex products	<ul style="list-style-type: none"> • Sticky packaging • Discoloured product or lubricant • Stained packaging • Leakage of the lubricant (moist or damp packaging)
Pills (tablets)	<ul style="list-style-type: none"> • Discolouration • Crumbled pills • Missing pills (from blister pack) • Stickiness (especially coated tablets) • Unusual smell
Injectables	<ul style="list-style-type: none"> • Liquid does not return to suspension after shaking
Sterile products (including IUDs)	<ul style="list-style-type: none"> • Torn or ripped packaging • Missing parts • Broken or bent parts • Moisture inside the packaging • Stained packaging
Capsules	<ul style="list-style-type: none"> • Discolouration • Stickiness • Crushed capsules

Tubes	<ul style="list-style-type: none"> • Sticky tube(s) • Leaking contents • Perforations or holes in the tube
Foil packs	<ul style="list-style-type: none"> • Perforation(s) in packaging
Chemical reagents	<ul style="list-style-type: none"> • Discolouration

Taken from: [JSI - Guidelines for the Storage of Essential Medicines and other Health Commodities](#)

Signs of product defects can be caused by a variety of things and may be sign of a wider problem.

If any product displaying any form of above-mentioned defects is identified, logistics personnel should:

- Separate identified issues from general stock and stop any distribution or use of the items.
- Contact the product distributor and/or manufacturer and/or the organisations quality assurance specialists to see if there is a known cause or if the product may still be usable.
- Contact other storage sites or health facilities with similar products to see if the problem is occurring elsewhere.

Only after a proper course of action is identified should products be either disposed of or returned to general rotation. In the event that the product is damaged, and disposed of, mitigation measures should be implemented to prevent future damages to other items if within the control of the organisation/warehouse.

Recall Management

Throughout the course of any health-related supply chain, health practitioners may be faced with managing product recalls. A product recall occurs when a manufacturer or a local health authority indicates that one or more health items is considered unfit for human consumption and must not be distributed or used in routine activities. There are multiple reasons why a product may be recalled, including faulty production, product tampering, changes to local regulations, or some other defect that may impact the product's fitness for human consumption. Manufacturer's typically reference item batch or lot numbers when identifying recalled items, however entire product lines or even products from specific periods of production may be recalled. The important part is that the manufacturer or local health authority will provide specific criteria for what items should be recalled, and humanitarian actors should endeavour to comply wherever possible.

Recalled items are occasionally returned to the manufacturer, however in many contexts the owners of the health items will need to actively quarantine all recalled items and manage the destruction/disposal process directly. In most humanitarian contexts, pharmaceuticals and medical devices are frequently imported from outside the country of operation, and the process of collecting and re-exporting recalled items may be prohibitive or even impossible. Any time a recall occurs, logistics planners must assess what is feasible.

The general steps for recall management include:

- A product manufacturer or local health authority identifies a specific product, or products based on key criteria that should be recalled.
- (If possible) humanitarian organisations should reference all procurement and inventory tracking systems to understand if the recalled items are currently in their supply chains. Note: due to the complex or ad-hoc nature of humanitarian supply chains, this information may not be available. If no records are available, humanitarian organisations should act as if they have recalled items in their possession.
- Humanitarian organisations should immediately contact all warehouses, storerooms, health facilities, or other locations where recalled products might have been sent. All locations should be informed to do a full inventory to identify any and all recalled items. Identified recalled items should be segregated from the primary inventory items and placed in a secured quarantine area.
- (If required) humanitarian organisations should contact local communities, ministry of health offices and partner organisations that might have received recalled goods as part of regular programmatic activities and inform each party of which items have been recalled, and what steps they should take to safely secure recalled items. Depending on the context, the humanitarian organisation may be required to retrieve all recalled items directly from each outside party in order to avoid any mismanagement or accidental distribution.
- (If required) The humanitarian organisation in question may have to organise the pick-up and relocation of all expired items to the capital city or primary distribution facility to enable proper return or disposal of the recalled goods. In many humanitarian contexts, there may be no local infrastructure to support disposal at the local level.
- In every context, there may be different steps required for the proper disposal of recalled items.
 - Manufacturers may offer or may be obliged to pick up recalled items directly from organisations managing the items themselves.
 - Local or national health authorities may have dedicated facilities or means to pick up or receive specific recalled items.
 - Local or national regulations may require that recalled health items be disposed of by the product owner in specific way, or that some items be re-exported. In the event items are re-exported, special permits will likely be required.

Even if there is no specific regulation in place, humanitarian organisations should seek to properly dispose of recalled items using the most ethical and environmentally friendly methods available. Proper disposal methods can be found in the section on [managing medical waste](#).

Medical Waste Management

While supporting any form of medical intervention, logistics personnel may be asked to manage a variety of medical waste. Medical waste isn't defined as just the health items that are found as damaged or expired while in storage or transport, but also the byproduct of routine activities that occur in health centres and hospitals as well.

Waste categories	Descriptions and examples	
Hazardous health-care waste	Infectious waste	Waste known or suspected to contain pathogens and pose a risk of disease transmission, e.g. waste and wastewater contaminated with blood and other body fluids, including highly infectious waste such as laboratory cultures and microbiological stocks; and waste including excreta and other materials that have been in contact with patients infected with highly infectious diseases in isolation wards.
	Sharps waste	Used or unused sharps, e.g. hypodermic, intravenous or other needles; auto-disable syringes; syringes with attached needles; infusion sets; scalpels; pipettes; knives; blades; broken glass.
	Pathological waste	Human tissues, organs or fluids; body parts; foetuses; unused blood products.
	Pharmaceutical waste, cytotoxic waste	Pharmaceuticals that are expired or no longer needed; items contaminated by, or containing, pharmaceuticals. Cytotoxic waste containing substances with genotoxic properties, e.g. waste containing cytostatic drugs (often used in cancer therapy); genotoxic chemicals.
	Chemical waste	Waste containing chemical substances, e.g. laboratory reagents; film developer; disinfectants that are expired or no longer needed; solvents; waste with high content of heavy metals, e.g. batteries, broken thermometers and blood pressure gauges.
	Radioactive waste	Waste containing radioactive substances, e.g. unused liquids from radiotherapy or laboratory research; contaminated glassware, packages or absorbent paper; urine and excreta from patients treated or tested with unsealed radionuclides; sealed sources.
Non-hazardous or general health-care waste	General waste	Waste that does not pose any specific biological, chemical, radioactive or physical hazard.

Taken from: [WHO - Safe management of wastes from health-care activities](#)

Medical waste can pose specific threats to humans, animals and the environment, and must be handled appropriately. Infectious waste and pathological waste products in particular are highly sensitive and should only be handled by experts that understand the process, while all of the aforementioned medical waste items are likely subject to some form of regulation or control.

International conventions such as the [Basel Convention on the Control of Transboundary Movements of Hazardous Wastes](#) or the [Stockholm Convention on Persistent Organic Pollutants \(POPs\)](#) in particular define the waste management policies for signatories, however national or local laws may also outline the procedures. The important thing for logistics personnel to know is that any form of medical waste disposal must be done in a safe and lawful manner. Under no circumstances should medical waste be disposed of with general waste.

Traditionally, the aggregation and storage of medical waste is not the role of logistics personnel and is usually left to healthcare professionals operating in medical facilities. Due to limitations on personnel and resources, logistics staff in humanitarian field settings may be required to facilitate the handling, storage or transport of medical waste.

Segregation of Medical Waste

Though local conditions may vary, as a best practice healthcare facility should segregate waste into four categories, each of which should be stored, collected and disposed of separately. The four categories are:





1. Sharps waste (needles and scalpels, etc.), which may or may not be infectious.
2. Non-sharps infectious waste (anatomical waste, pathological waste, dressings, used syringes, and used single-use gloves, etc.).
3. Non-sharps non-infectious waste (paper and packaging, etc.).
4. Hazardous waste (expired drugs, laboratory reagents, radioactive waste and insecticides, etc.).

Almost 85% of medical waste in health centers or hospitals belong to the category of non-sharps non-infectious waste. Any waste item that is cross-contaminated with infectious waste should be considered infectious waste as well, and proper segregation of non-sharps non-infectious waste from infectious waste can significantly reduce the total amount of infectious waste in a health facility. However, in many humanitarian contexts hazardous and non-hazardous healthcare waste is often not separated. If proper segregation cannot be ensured at source, consider all mixed healthcare waste as hazardous.

Medical Waste Collection

Collection and storage of medical waste must be done using suitable storage containers. If no suitable containers are available, humanitarian organisations are strongly advised to procure the appropriate storage containers. As hazardous waste is collected, each container should be properly labelled, and collected waste should be placed in a pre-defined, secure location.

WHO has recommended coding and storage for some medical waste storage, including symbols, colour coding and marking. Recommendations for some common medical waste items are:

Type of waste	Colour coding	Symbol	Type of container
Household refuse (non-sharps non-infectious waste)	Black	None	Plastic bag
Sharps	Yellow and marked with a biohazard symbol:		Sharps container
Waste entailing a risk of contamination and anatomical waste	Yellow and marked with a biohazard symbol:		Plastic bag or container
Infectious waste	Yellow marked "highly infectious" and marked with a biohazard symbol:		Plastic bag or container which can be autoclaved
Chemical and pharmaceutical waste	Brown, marked with a suitable symbol (example)		Plastic bag, container

Adapted from: [ICRC - Medical Waste Management Guidelines](#)

Common storage container examples and practices include:

- Sharps should be placed immediately after use in yellow puncture-proof, covered safe sharps containers, which are regularly collected for disposal. Containers must not be filled above the line indicated on the label, and they must be sealed using the integrated safety lock prior to disposal.
- Non-sharps infectious waste should be placed in yellow or red infectious waste bags or containers (15–40-litre capacity with lids). Bags should be collected and replaced after each intervention or twice daily. Containers should be emptied, cleaned and disinfected after each intervention or twice daily.
- Non-sharps non-infectious waste should be placed in black waste containers (20–60 litre capacity). The containers should be collected, emptied, cleaned and replaced daily; alternatively, plastic bags may be used as liners inside the containers.

Adapted from: [WFP Logistics Cluster - Downstream Logistics in Pandemics](#)

For each of these three waste categories, it is recommended that waste containers are kept no more than five metres from the point of waste generation. Two sets of containers should be provided for each location, for a minimum of three types of waste, or as is required by the activities in the health facility. In hospital wards, at least one set of waste containers should be

provided per 20 beds.

Example Sharps Container

Example Biohazard Bag



Personal Protective Equipment:

Any persons tasked with collecting and handling medical waste should have the proper and necessary personal protective equipment (PPE). This may include protective eyewear, rubber gloves, aprons, respirators, and the proper body covering. Prior to handling any and all medical waste, personnel should consult with the attending medical staff about the appropriate handling protective equipment. Remember: some health related waste can be extremely hazardous or even lethal if handled incorrectly. If ever logistics personnel are in doubt about the safety of handling medical waste, they should cease activities and consult with a trained professional.

Medical Waste Storage

The storage of medical waste can and will be regulated by prevailing local and national laws. Humanitarian organisations may also have internal guidelines or regulations on storage of medical waste. As an overall rule, humanitarian responders must check on local regulations before designing storage options. Medical waste should also be handled by experienced professionals when and wherever possible. Below are general best practices that *may* be adopted if needed:

General non-hazardous waste storage	<p>General non-hazardous waste should be stored and kept for collection to recycle (where possible), dispose at a communal landfill/dumpsite, or as a last resort destroyed at communal waste incinerator. It should be collected at least every week. The storage area should be enclosed, paved and connected to a public road. The gate should be big enough that the collection vehicles can enter. If available in the location, non-hazardous cardboards, metals, plastics, paper can be sorted and recycled by local contractors and avoid the need for disposing of in landfills or incineration.</p>
Infectious and sharp waste storage	<p>The storage place must be identifiable as an infectious waste area by using the biohazard symbol. Floors and walls should be sealed or tiled to allow easy cleaning and disinfection. Storage times for infectious waste (e.g. the time gap between generation and treatment) should not exceed the following periods:</p> <ul style="list-style-type: none"> • Temperate climate: 72 hours in winter/48 hours in summer. • Warm climate: 48 hours during the cool season/24 hours during the hot season. <p>If a refrigerated storage room is available, infectious waste can be stored for more than a week cooled to a temperature no higher than 3°C to 8°C.</p>
Pathological waste storage	<p>Pathological waste is considered biologically active and gas formation during the storage should be expected. To Minimise the possibility of this happening, storage places should have the same conditions as for infectious and sharps wastes. Where possible, waste should be stored under refrigerated conditions. In some cultures, body parts are passed to the family for ritual procedures or are buried in designated places. Bodies should be placed in sealed bags prior to release to the family to reduce the risk of infection.</p>
Pharmaceutical waste storage	<p>Pharmaceutical waste should be segregated from other wastes. International and local regulations should be followed for storage. In general, pharmaceutical wastes can be hazardous or non-hazardous, liquid or solid in nature and each type should be handled differently. The classification should be carried out by a pharmacist or other expert on pharmaceuticals.</p>
Storage of other hazardous waste	<p>When planning storage places for hazardous chemical waste, the characteristics of the specific chemicals to be stored and disposed of must be considered (i.e. inflammable, corrosive, explosive). The storage area should be enclosed and separated from other waste storage areas. Storage facilities should be labelled according to the hazard level of the stored waste.</p>
Radioactive Waste Storage	<p>Radioactive waste should be stored in compliance with national regulations and in consultation with the radiation officer. It should be placed in containers that prevent dispersion of radiation and stored behind lead shielding. Waste that is to be stored during radioactive decay should be labelled with the type of radionuclide, date, period of time before full decay and details of required storage conditions.</p>

Taken from: [WHO - Safe management of wastes from health-care activities](#)

Treatment and Disposal

The process for safe and adequate disposal of pharmaceuticals and health related items in contexts where humanitarians may operate has evolved significantly over the past several decades. Many state and local authorities now have strict regulations on the process of disposing of health waste and may include requirements far beyond the capacities of most individual humanitarian organisations.

As a primary rule, aid agencies should seek to outsource the destruction of medical waste to licensed and recognised third parties, including private companies, or through state managed entities such as local Ministries of Health. Aid agencies should also seek to understand and respect all local laws wherever applicable. Proper disposal usually has a cost associated with it, and organisations should budget for potential disposal costs.

In any situation where waste is disposed of using a third party, or by the organisation following national protocols or WHO guidelines (subject to regulatory framework), proper documentation must be retained and backed up to prove disposal was undertaken in a lawful manner. Even where disposal is done informally in large scale emergencies, the process must be documented to avoid the suspicion of diversion or health related items, or to avoid the suspicion that expired, damaged, or recalled items were handed out to beneficiaries, or sold illegally.

The [Logistics Capacity Assessments](#) website can provide humanitarian organizations with contact details for licensed waste management companies, overviews on local regulations and procedures in country including medical waste, and lists the existing waste management and recycling facilities in country.

In extraordinary situations, humanitarian organisations might be required to dispose of their own medical waste. Some steps might include:

- Sharps should be disposed of in a sharps pit. In small health centres or emergency structures, sharps pits may simply be buried drums; in other settings, they might be concrete-lined pits. For safety reasons, it is not advisable to use a decentralized facility to handle collection and off-site treatment and disposal. However, in urban situations this may be unavoidable due to lack of space.
- In small healthcare settings, non-sharps infectious waste should be buried in a pit fitted with a sealed cover and ventilation pipe for on-site treatment. Alternatively, it should be high temperature incinerated or steam sterilized either on-site or off-site. Special arrangements may be needed to dispose of placentas according to local custom. The preferred option for specific infectious waste (such as blood samples, plastic syringes and laboratory tests) is steam sterilization before disposal. This avoids environmental pollution from incineration. One autoclave should be dedicated for waste sterilization. The autoclave used for sterilizing medical devices within the laboratory must not be used for this purpose.
- Non-sharps non-infectious waste should be buried in a pit, a landfill site, or preferably recycled with non-food and non-medical items. If space is limited, non-sharps non-infectious waste should be incinerated. Ashes and residues should be buried in a pit.
- There are several kinds of hazardous waste, and each requires specific treatment and disposal methods. These include encapsulation, sterilization, burial, incineration and long-term storage. Some waste, such as pharmaceutical waste, cannot be disposed of in low-cost settings and should be sent to a large centre for destruction or returned to the supplier. In all cases, national regulations should be followed.

Waste Disposal Zones

In locations where agencies must dispose of their own medical waste there are basic

guidelines on the physical locations for disposal.

- The waste disposal zone should be fenced off and should be located at least 30 metres from groundwater sources.
- It should have a water point with soap or detergent and disinfectant for handwashing or to clean and disinfect containers, and it should have facilities for wastewater disposal into a soakaway system or sewer.
- Where an incinerator is used, it should be located to allow effective operation with minimal local air pollution in the health centre, nearby housing and crops, and it should be large enough for extension if new pits or other facilities have to be built.

WHO has published guidelines on the [safe disposal of unwanted pharmaceuticals](#) including strategies for prevention, reusing, returning and safe disposal, in and after emergencies, and the [safe management of wastes from health-care activities](#). In the event that agencies must dispose of their own medical waste, they are encouraged to speak with local Ministries of Health or other relevant body and consult with representatives from the local health cluster if available.

Transport of Medical Items

Transporting Temperature-Regulated Medical Items

The transportation of medical relief items, including medical relief items that require temperature controls of various kinds, is an increasing component of modern humanitarian response activities. Agencies responding to any given emergency will be confronted with a variety of transportation decisions based upon handling needs and local regulations.

Many of the same GXP/GSP/GDP requirements for storage also apply for transportation. The transport and movement of medical items, particularly drugs, needs to be carried out in such a way as to prevent deterioration of the quality of the items, and in a way to also prevent the infiltration of counterfeit and substandard items into the supply chain or the theft of valuable items. Key considerations include:

- The specific requirements for temperature-regulated medicines.
- Ideally transport containers of medical items, particularly drugs and medical devices, should not be used for other goods (especially food and fuel). Where not possible, they must be packed separately and clearly marked as medical items and should be protected from other items (e.g. items using a tarpaulin).
- The quality of medical items can be significantly affected during their loading and unloading during transport.
- The fragile nature of many medical items requires dedicated attention and oversight in loading and off-loading, as well as transport method selection.
- Sufficient security measures for controlled substances should be put in place.
- Documents should be maintained with the goods containing expiration dates, countries of origin, or other information as required by local authorities.

It is important to keep in mind that some countries have requirements for certification to transport medicines domestically (GDP certification) as well as strict requirements for the transportation of narcotics.

Depending on the external ambient temperature, stability of the product and length of the journey, temperature-controlled transport solutions may be required for the majority of medical items - including those requiring +15°C to +25°C storage ranges.

Evaluating the Journey

To evaluate the journey, some of the criteria to be consider are:

- The transport modes and vehicle types.
- The journey distances and its expected duration.
- The environmental conditions: temperature (day–night and seasonal temperature extremes) and geographical and natural hazards.

There are 3 basic transportation stages in the supply chain of temperature-controlled medical items:

1. From the manufacturer to a primary or central store: usually international shipments.
2. Between (intermediary) stores: normally between national or district store facilities and down to the health care facility.
3. Outreach transportation: final keep cool item delivery during regular EPI or to a vaccination site during a mass vaccination campaign.

Evaluating the entire journey can reveal gaps, such as lack of temperature-controlled storage at customs, or excessive lead times to delivery cargo items down-stream. It is strongly advisable for humanitarian organisations to consider the entire journey when shipping medical relief items, especially those with time sensitive and temperature-control requirements.

Aerial or terrestrial modes are preferred for transportation of items that are time sensitive, or carried in passive cold chain containers. Air transport is usually chosen for international or long-distance shipments. In most humanitarian contexts, terrestrial land transport is usually for transport of items carried in passive keep cool container within the same country, unless refrigerated trucks are readily available in the context. Outreach is often done by any land transport mode: car, motorcycle, bicycle. Because of the long duration of the journeys, passive keep cool containers are rarely transported through waterborne means.

Enacting Shipments of Temperature-Controlled Medical Items

Shipment Documentation

Having the proper documentation in time is critical for any shipment of time sensitive temperature-controlled medical items as any delay might expose the items to inappropriate temperature conditions, especially through cross-border supply chains. In the event of international shipments, the shipper must provide the cargo details with sufficient time in advance to allow the consignee to prepare for the reception. In addition to the commonly accepted [standard set of shipping documents](#) and [documents associated with importation](#), shippers should review all required shipping documents prior to shipping with relevant customs broker and health authorities. Ideally, all documents and information should include:

- Date and time for place of departure, transit (if applicable), and arrival.
- Any temperature requirements.
- Type of item, total number of primary containers/vials and number of doses per primary container/vials.

One set of the original documents above must also be placed inside the parcel numbered "1". This particular parcel should be clearly labelled with the words "Containing shipping documentation".

Any time temperature-controlled medical items are to be transported using commercial carriers, humanitarian organisations will still need to specify and declare key information up front. This will include.

- Maximum and minimum temperature ranges.
- (If required) [Supplying safety data sheets](#) (SDS) for live vaccines, chemical coolant packs, or anything else that might qualify as dangerous goods.
- Sufficient security measures for controlled substances.
- Documents containing expiration dates, countries of origin, or other information as required by local authorities.

For shipping vaccines – Additional documentation may be required, including:

- Lot Release Certificate issued by the national regulatory authority (NRA) of the country of manufacture for each lot of items in the shipment, together with the Certificate of Pharmaceutical Product (also by the NRA).
- Lot Summary Protocol of production and quality control.

A list of contact points for national regulatory authorities in countries producing vaccines pre-qualified for purchase by United Nations agencies can be found in [WHO Guidelines on the international packaging and shipping of vaccines](#).

Air Shipments

Temperature sensitive shipments must be booked to the air company under the proper handling code and as “temperature-controlled health-care cargo”, as this is an exceptional service beyond that offered for general cargo.

Road Shipments

For road shipments, it is critical to coordinate the delivery with the consignee before dispatch and confirm pick-up time and location.

To reduce as much as possible the temperature-controlled medical items are outside active devices and to exploit cold life of any used passive containers, prepare and pack products in its designated packaging the same shipping day.

If using a third-party logistics provider, make sure that they are prequalified and approved for freight forwarding/transport.

If time sensitive temperature-controlled medical items through a third-party transporter:

- Ensure the transporter knows the exact limits on time for deliver.
- Include clear instruction on handling requirements of keep cool boxes/items.

If a humanitarian organization is organising the shipment by own means, it is best practice ensure that the designated vehicle is in good working condition and that the driver is aware of the cargo sensitiveness. Provide the driver with clear instructions and the necessary means to ensure proper load, handling and transport. This should include:

- Using refrigerated vehicles where possible. If refrigerated vehicles are not available, place temperature sensitive items in shaded areas.
- Fragile boxes/containers should be secured.
- Use of shaded and secure parking areas, minimising the time during which the vehicle is unattended.

- Avoid opening the refrigerated vehicle or keep cool containers during transit.
- Emergency contact information to call in case of breakdown or unexpected events.

The arrival of a temperature-controlled medical items in a country, and their subsequent clearance through customs and transportation to a central store are the most critical stages in the shipping process. These are frequently the times when mistakes and delays occur, resulting in damage or loss of items.

Receiving Temperature-Controlled Medical Items

Reception at Customs

Clearing of any items through custom should follow the normal procedures of that country, however there are few extra things logistics personnel should consider temperature-controlled medical items.

The first step in the customs clearance process, is contacting the following entities to obtain or verify the import procedures:

- National regulatory authorities (NRA) or head of customs in the destination country. To be cleared, the imported items must have received marketing authorisation and a release certificate from the national regulatory authority.
- Local Ministry of Health (MOH): depending on country specific requirements, the MOH may issue a letter approving the shipment.

As reference, the general steps are:

- Submission of shipping documents (as soon as they are received) with a request to customs authority for the provisional clearance of shipment to the nominated Clearing and Forwarding agent.
- The clearing and forwarding agent immediately processes the shipping documents as per established rules and regulations of government and contacts customs and airlines to coordinate the arrival, transport, checking and safe storage of the items.
- Continuous contact is maintained well in advance with the concerned airlines to get accurate and updated information of the flight arrivals of the shipments.
- Once the flight/vehicle arrives, immediate action is taken to release and take delivery of the keep cool shipment and to safely transport the items to the temperature regulated storage locations.
- The clearing and forwarding agent checks the cold-chain monitor(s) and other mechanism (if necessary) to identify and reconfirm that the temperature-sensitive items arrived in good condition before removing the shipment from the airport.
- Irrespective of the condition of the temperature-sensitive items at the time of clearance, the clearing and forwarding agent clears the items and delivers as per regular procedures.
- The clearing and forwarding agent informs the concerned official(s) in a timely manner and arranges for the cold room and the required staff to be ready and available to receive/store the keep cool items.
- There should be a system in place to arrange to open the cold room and liaise/contact with the storekeeper/cold room staff at any time (24-hours/day, including weekends and holidays).
- Under no circumstances can any temperature-sensitive item be left unattended, or outside of the cold room in an open space.
- Unannounced shipments are cleared in time, like all other shipments.

- A reliable transport system including a refrigerated/insulated van should be made available at all times for effective transportation and delivery of the keep cool items.

In special instances where regular customs procedures may not be in place – such as extraordinary emergency conditions or use of military aircraft - humanitarian organisations may have to be prepared to receive keep cool shipments under their own volition. This includes having the adequate vehicles waiting at the point of reception and providing the receiving party with all anticipated times of arrival and handling instructions.

Importing temperature-controlled medical items through ports that don't have the adequate cold storage facility is not recommended. In the event of receiving a shipment of needing clearance in a port without cold storage facility or if the cold room is inaccessible, arrangements should be done for immediate release of the shipment. Coordination with the relevant authorities for an agile clearance and/or for safe and appropriate management and storage of emperature-controlled medical items at the airport are therefore needed.

Reception at the Storage Facility

Any reception facility receiving medical items that have temperature control requirements, other other specialty handling needs should have the capacity to receive and adequately store medical items in the proper way. Prior to shipping any medical items, humanitarian organisations should evaluate if storage facilities can safely receive and store those medical items.

Ensure priority unloading of all shipments of temperature-controlled medical items. If multiple vehicles arrive at the same time, prioritize unloading the most time sensitive items, or the items that have the shortest capacity for transport (items contained in passive cold chain containers)

Move the product immediately to the appropriate place in the storage facility. Open packaging, retrieve and inspect the temperature monitors, remove product from its passive shipping container and move it immediately to the correct temperature-controlled storage conditions.

If the temperature monitor shows a change that indicates potential deviation, take a picture, photocopy or scan that show alarm status. This information should be used to make decisions on whether to accept the product, or whether to quarantine it until an investigation has taken place and a final disposition has been made.

If using dataloggers or tags that record time and temperature data that can be downloaded, retrieve and store time and temperature data. The point in time when a temperature excursion has occurred is important for the purchasing agency and/or the manufacturer so they can identify the cause of the excursion, take corrective measures, avoid similar situations in future shipments, and for insurance purposes.

Clearly identify temperature-controlled medical times in boxes in which the indicator shows exposure to temperatures that risk damage and keep them at the required temperature for further assessment of their condition. Do not discard potentially damaged items until a full assessment is completed.

Verify that all necessary documents are present. *In the case of vaccines*, do not use the vaccines if the lot release certificate is missing. In that case, keep vaccines on hold in cold storage until the relevant document has been obtained from the vaccine manufacturer.

Report any relevant information to the carrier and to the appropriate personnel in your organisation. In case of loose or damage, review insurance policy clauses and follow the

insurance claim instructions.

Labelling Containers of Medical Items

Containers carrying temperature regulated medical items should be properly labelled with the handling and temperature requirements on the side. Specific requirements exist for the labelling of international/air shipments. Therefore, a distinction must be made between international/air and domestic shipping.

International/Air Shipments

For international/air shipments, a label must be affixed to the front surface of each package indicating type of item, name of manufacturer, presentation, batch number, date of manufacture, date of expiry, quantity, and storage conditions. The manufacture date and expiry date on all labels should be written in full, not in a coded form (i.e. June 2017, not 06.17). In addition, required temperature conditions for transportation must be clearly visible on the outer carton, indicating clearly where recommended transportation temperatures differ from recommended storage temperatures.



A "Vaccine Rush" Label must be affixed to each face of the vaccine package



A "Do Not Freeze" label must be affixed to those packages (in each face) containing freeze-sensitive vaccines, droppers or diluents.



An IATA Time and Temperature Sensitive Label (mandatory from 2012). The lower half of the label must never be left blank and must indicate the external transportation temperature range of the shipment - this can be handwritten or printed onto the label.

Labels must be written in a language appropriate to the country of destination.

Domestic/Road Shipments

There is no specific international regulation for labelling medical shipments transported by road. Nevertheless, becoming knowledgeable in the laws of all of the countries in your distribution channel can help to avoid administrative burden and delivery delays.

In any case it is recommended that shipper and consignee agree on a basic standard operational procedure to pack, label and receive temperature-controlled medical shipments. Among other topics, the procedure should establish the warning signs about time and temperature sensitiveness of the parcels, and shipping labels should indicate temperature requirements on the outside.

Temperature Monitoring Devices for Transportation

Much like monitoring temperatures in a warehouse, there are a variety of temperature monitoring techniques and devices available for monitoring temperature of health related items while in transit. These devices can come in the form of:

- **Electric** – Devices that require power and can usually interface with a computer.
- **Chemical** – Monitors that rely on chemical reactions to produce indications of temperature conditions.

- **Passive** – Temperature indicators cannot or do not communicate with external servers or alarms.
- **Active** – A device that has the capacity to send continuous data to a central data point and can be used to see temperatures in real time.

The requirements for duration of shipments, required temperature ranges, reusability needs, access to basic infrastructure, real world conditions on the ground, and other key needs will dictate the types of monitoring devices used. In modern humanitarian contexts, the last mile delivery of humanitarian supplies usually operates without adequate temperature-controlled transport or monitoring. In the event that adequate temperature monitoring for all items isn't available, prioritisation of data loggers for the most sensitive and high risk products should be ensured. Continual monitoring of pharmaceutical and health items that should be kept at the +15°C - +25°C range may not be required in all situations, and humanitarian agencies may only wish to enact monitoring upstream or in more stable conditions. At the same time, local or national laws may actually require all temperature-controlled shipments to be monitored at all times, with documented evidence.

Agencies operating in humanitarian contexts should build a monitoring plan that makes sense based on the requirements on the ground. In the event that there are bottlenecks in end-to-end temperature monitoring, mitigation measures can be implemented, such as random inclusion of a single datalogger for an entire consignment, with collection and analysis by the organisation after supplies arrive to the point of use.

Additionally, active temperature monitoring devices tend to be too complex, too expensive, or otherwise require training and infrastructure that isn't available in most humanitarian contexts. Commercial service providers will frequently employ active monitoring in large international shipments, or for entire vehicle loads such as reefer trucks or reefer containers, but individual humanitarian organisations will likely require a variety of monitoring techniques when and where required. Some of the more common passive temperature monitoring devices might include:

Temperature Dataloggers – Temperature dataloggers have become the most commonly use temperature monitoring devices for most medium to small shipments. Temperature dataloggers are small, electronic and usually passive monitoring devices that can continually monitor temperature for up to weeks at a time, depending on the device. The advantage of a temperature datalogger is that it displays a chronological "history" of the temperature conditions as long as the device was turned on, and shippers can witness fluctuations in temperatures or even see multiple temperature excursions time-stamped against real world events. This will help shippers identify problems and work with transport companies and employees to fix problems.

There are a variety of datalogger devices available on the market, including dataloggers that can plug directly into USB ports and download data, dataloggers that have electronic displays on the side, dataloggers that have programmable temperature ranges, and dataloggers that can be recharged and reused. The overall type and requirement for the datalogger brand depends on the needs of the shipper.



Once activated, temperature dataloggers can be dropped into a box or package of health items and retrieved on the other end. Temperature dataloggers can therefore be used when shipping single boxes, or when shipping pallets or large volumes of items, and can be used when shipping across multiple carriers or multiple modes of transportation.

When using temperature dataloggers, humanitarian organisations should:

- Understand what their overall requirements are – what temperature ranges are required, how long will monitoring be required, will the reuse of the device be required?
- Consult the manufacturer guidelines and instruction manuals.
- Ensure that both senders and receivers understand how to use the devices and understand their importance.
- Have a plan for recovering and backing up data from temperature dataloggers at points of reception and have a plan for reviewing data and taking corrective steps in case of any identified problems.

New advancements in technology are always underway, and newer versions dataloggers are continually being developed. Logistics personnel should conduct a market survey of the latest technology when selecting a product.

Chemical Indicators - Also called markers or phase-change indicators). They are the most accessible and easy to use, they are based in a chemical impregnated onto a paperboard that changes its appearance under certain temperature. There are two types of chemical indicators:

1. Threshold type.
2. Progressive type.

Threshold Type chemical indicators provide a signal only when exposed to temperatures higher than (ascending indicator) or lower than (descending indicator) a predetermined threshold temperature. They are irreversible (thus, single use) and are suitable for high or low temperatures.

Example of these devices are:



Progressive Type chemical indicators register multiple events in a cumulative way. Whenever the threshold temperature is exceeded, the reaction is activated, and the indicator starts to change. Further temperature violations increase the change process. The indicator for this type of device usually takes the form of a progressive colour change along a paper strip.

Vaccine Cold Chain Monitor				
Date in	Index	Location	Date out	Index

3M MonitorMark
INDEX/INDEXE 10°C 36°C

A B C D

If A all blue If B all blue If C all blue If A & B & C & D all blue

Polio	Use within 3 months	TEST VACCINE BEFORE USE
Measles & Yellow Fever	Use within 3 months	
DPT & BCG	These vaccines may be used	
TT & DT & Hepatitis B		

SUPPLIER FOURNISSEUR

Name: _____
 Nom: _____
 Date of dispatch: _____
 Date d'expédition: _____
 Vaccine: _____
 Vaccin: _____

Cold Chain Monitor (CCM) Card

Paper-based temperature monitoring device which change colour irreversibly and at a constant rate. Indicator strips are attached to a card on which instructions for use are printed.

CCMs provide a warning when excessive heat exposure occurs during transport. They are used primarily to monitor the international shipment of freeze-dried vaccine consignments where dry ice is used. CCMs may also be appropriate for national vaccine shipments where the delivery takes several days.



Vaccine Vial Monitor (VVM):

Heat-sensitive label that gradually and irreversibly changes colour as the vaccine is exposed to heat. It warns the health worker when a vial should be discarded because the vaccine is likely to have been degraded by exposure to heat. For instructions on how to interpret VVM, refer to WHO [How to Monitor Temperatures in the Vaccine Supply Chain](#)

Electronic Freeze Indicators - used to check if shipments are exposed to freezing temperatures during storage or transport. The alarm indicator is triggered and displayed (changing from a "□" to an "X") if exposed to temperatures lower than -0.5°C for a continuous period of 60 minutes. To avoid malicious manipulation, once the alert is triggered, the alert is irreversible. If this happens the device is no longer usable and should be discarded. Otherwise, the device can be used until the built-in battery expires. The intermittent "dot" icon confirms active monitoring.



Electronic Shipping Indicators - more sophisticated devices that show if a product has been exposed to temperatures beyond the assigned alarm settings. They record the temperature at regular intervals during a certain period (normally not exceeding 20 days due to memory overflow). They have a digital display that reflects if the item being shipped crossed the alarm thresholds.

Shipping indicators are mounted on a coloured card (yellow or blue) with a data entry section on one side, which the manufacturer fills in at the point of dispatch, and an instruction and interpretation section on the reverse side for the recipient. Yellow indicators are for freeze-sensitive items, and blue indicators are for heat-sensitive items.

These devices are not re-usable once alarm conditions are triggered or the programmed time elapses. In addition, the heat and/or freeze alarm thresholds are product-specific, which means that the device is not reusable with different products than originally intended. Some brands are able to download the temperature data to a computer. This enables recipients to determine whether shipments have been exposed to excessively high or low temperatures; it also helps the procurement agency to determine when, where and to what extent temperature limits have been exceeded.



Active Cold Chain Transportation

Active cold chain transport methods broadly refer to any method of transportation that provides supplemental power, mechanical or chemical processes to maintain temperatures while cold chain items are in transit. Active cold chain can come in a variety of forms – the transport method itself could be completely refrigerated, or supply power to self-contained containers that have a cooling effect on the required cargo. Active cold chain equipment can come in many sizes and form factors but is generally better suited for large volumes of temperature regulated health items, or when local regulations require it. Active cold chain transport items can typically be calibrated to a specific set point, which is adjustable based on the transport needs.

Refrigerated Road Vehicles

Refrigerated road vehicles come in a variety of formats, but generally are characterised by:

- Rigid, enclosed structures.
- Active cooling from permanently mounted air conditioner or freezers that draw power either directly from the engine of the vehicle, or specialised independent motors.
- Insulated interior walls/ceiling/floor.
- A tightly closing, sealable door or doors with proper insulated lining.
- An electronically controlled thermostat with an adjustable set point.
- Some refrigerated vehicles have built in alarm systems in case of a temperature excursion.

Refrigerated vehicles can come in the form of:

- Vans.
- Single unit box trucks.
- Semi-trailers.

The most common type of refrigerated vehicle used in humanitarian contexts is the single unit refrigerated box truck, usually referred to as a “reefer truck”, however this may vary from context to context.

Example refrigerated box truck, with insulated walls and self-contained freezer unit at the highest point of the container.



It is highly unlikely that humanitarian organisations will directly own their own reefer trucks or other refrigerated vehicles unless there is a fully dedicated project that would justify the expense. In the event that the vehicle is owned, humanitarian organisations should refer to the [fleet management](#) section of this guide consider all regular requirements associated with [maintaining their own trucks](#).

In the highly likely event that humanitarian organisations contract third-party transport services to utilise a refrigerated road vehicle for transport, they should consider [the normal procedures associated with contracting any trucking service](#). Additionally, there are a few additional contractual terms they should consider when soliciting third party refrigerated vehicles.

Contracting Third Party Refrigerated vehicles:

Recommended Terms - Temperature-Controlled Movements / Requirements

In the case of the movement of temperature-controlled goods, the following terms are recommended for contracting and soliciting third party refrigerated vehicles.

- If required, the contracted trucking company should ensure that the cooling units have been programmed for permanent run prior to loading per instructions.
- Contracted trucking company should ensure a copy of a valid calibration report is present in the truck.
- Contracted trucking company should ensure the driver maintains an activity sheet where temperature readings are recorded at every transition / touch point / stop point.
- Drivers should remain present at the dock area while goods are being loaded at origin and offloaded at destination.
- Drivers should ensure doors are closed immediately after loading. Doors should be barred and locked if required.
- Whenever the trailer doors have to be opened, including but not limited to loading, offloading, they should be closed immediately after-wards to avoid temperature disparities.
- In case of any customs or third-party inspection, the contracted trucking company should inform contracting agency immediately, detailing door opening and closing duration and

the temperature readings should be recorded on the activity sheet.

- The contracted trucking company should provide calibrated and proper functioning reefer equipment and ensure the driver checks the temperature and the reefer equipment's running status at every stop.
- In case of irregularity / temperature variance the contracted trucking company should inform the contracting humanitarian agency immediately.
- The contracted trucking company should make sure the drivers do not remove any temperature monitors / data recorders once they are placed inside the trailer until the truck reaches the point of delivery.
- The contracted trucking company has to ensure temperature monitors / data recorders are to be brought back after delivery.

Temperature Variances / Deviations

- In case of deviations from the terms and conditions contained in this agreement/contract the driver should notify the contracted trucking company, who should communicate this with the contracting humanitarian agency immediately.
- The contracted trucking company should make sure an investigation is done in case of a complaint / temperature variation issue is raised by the contracting humanitarian agency with regards to the temperature variances.
- In any case of claim/complaints the contracted trucking company and contracting humanitarian agency will study the case, should provide the corrective and preventive actions and then proceed with the claim process and procedures.

Maintenance and Calibration

- The contracted trucking company should ensure the reefer system used for transporting temperature-controlled goods should undergo regular preventive maintenance.
- The contracted trucking company should ensure the reefer trucks used are calibrated annually and should be certified.
- Contracted trucking company should provide the contracting humanitarian agency with the records of truck maintenance and calibration certificates upon request.

A general checklist on how to enact road shipments using a refrigerated vehicle can be found below:

- Pre-shipment actions:***
- Specify temperature requirements.
 - Prepare shipping documentation and checklists, especially as it pertains to transport of specialty medical items.
 - Ensure that the designated vehicle is in good working order, that its service record is up-to-date, and that the driver has carried out the relevant daily safety inspection.
-

**Shipping day:
actions at
point of
origin:**

- Pack the product in its correct tertiary package and attach temperature-monitoring devices to suit the routing requirements. Keep product under proper storage conditions until the time of dispatch.
- Ensure that the vehicle is fully operational, and that the cargo area is clean and odour-free.
- Prior to loading, the trailers should be at the temperature required for transport. Loading should only be initiated when the temperature reaches the set point requested by the contracting humanitarian agency.
- Keep loading door(s) closed until it is time to load the product.
- Ensure that the thermostatic controller on the transport vehicle is set to the required temperature and ensure that the temperature recording device(s) are operating properly.
- Check that the vehicle's refrigeration unit is operating properly, and that the temperature has stabilised. Drivers must ensure that the correct temperature setting has been selected.
- Load product without delay. Do not overload the vehicle. Allow for air circulation around all sides of the product. Properly block and brace the load, as shown in Annex 1, to avoid shifting during transit. Close door(s) and apply security seal and/or lock if required.
- Whenever possible, ensure that the driver is able to supervise the loading process.
- If the refrigeration unit has been operating on mains electric power during loading, make sure that the engine-powered refrigeration system is operating correctly, and that the temperature has stabilised within predefined limits before releasing.
- Provide clear instructions to the driver concerning the correct load temperature, handling and transport requirements.
- Provide emergency contact information to the driver.

Actions during transit:

- Cooling units must remain active throughout the entire journey, including during stops and rest periods.
- Energy-saving modes/options of the cooling unit should not be used.
- Vehicle payload doors must only be opened during loading and unloading and opening time must be kept to a minimum.
- Minimise the time during which the vehicle is unattended by the driver.

**Arrival day:
actions at
destination
point(s):**

- Ensure priority unloading.
- Remove product from the vehicle and move it immediately to a location providing the correct temperature-controlled storage conditions.
- Retrieve temperature data from the driver.
- (where possible) When the product is received, the consignee should retrieve and deactivate the temperature monitors accompanying the shipment and read and download the data. *Note:* If temperature monitors are not packed with the product, the data from the on-board temperature recording system should be downloaded, or a print-out obtained from the driver and attached to the arrival forms.
- Ensure all checklists and arrival forms are completed by the responsible parties.

It is very common for refrigerated vehicles to be opened and undergo inspection when crossing borders, or when operating around intense insecurity. Persons sending items using refrigerated vehicles should anticipate situations when enhanced inspection might happen, and how that might impact transported cargo.

Reefer Containers

A reefer container is a variation on a [standard shipping container](#) used in maritime operations, only with the capacity to maintain a constant temperature. Much like refrigerated trucks, reefer containers have self-contained freezer/refrigerator units, and proper insulation. Reefer containers can be transported on the backs of trucks, mounted onto the decks of sea vessels, or even be used as storage facilities.

Reefer containers usually come with both external power connections and self-contained motors used to power refrigeration equipment. As containers are moved, it's the responsibility of the transporter to ensure that the reefer produces constant power and will maintain a temperature to the relevant set-point. Reefer containers can be plugged directly into the electrical systems of large sea vessels, trucks or buildings. Where external power isn't available, reefers – depending on the container – reefers may be able to run an internal motor off of petrol or diesel, however the motors will have to be refuelled and maintained while the items are in transit.

Reefers and Sea Shipping

When reefer containers are utilised for sea shipping, they are almost always owned by either the shipping line, or an intermediary broker. Typically, the use of the reefer container is negotiated using a freight forwarder, and the overall loading and handling of the container is done outside of the control of the organisation or individual sending refrigerated items via ocean. In many cases, owners of refrigerated cargo won't even be involved with stuffing containers.

Example reefer container:



All reefer containers used for sea shipping must undergo what is known as a pre-trip inspection (PTI). Unless the reefer container is owned by the sender of the cargo, PTIs are undertaken by the shipping company. PTIs validate the condition of the container, the refrigeration equipment, and the monitoring equipment, and are rated for 30 to 120 days, depending on the needs of the shipping line and policies of the company.

Humanitarian organisations planning on using reefer containers to transport health supplies should still endeavour to inspect the container wherever possible.

- Even if a PTI is conducted by the transport company, shippers may request their own inspection if necessary, and include them in their own transport contracts.
- It is also advisable that organisations shipping cargo via reefer include the obligation of the shipping line to conduct a PTI in the contract – though the failure to fully conduct a PTI may ultimately be the responsibility of the shipping line, having a written agreement outlining the need for a PTI is still advisable.
- Organisations shipping cargo via reefer may also ask for copies of any monitoring reports that are produced throughout the shipping process. There may even online/real time monitoring capacity available through the transport company.

Reefers as Permanent Storage

Many organisations in humanitarian settings have opted to use reefer containers as permanent storage structures. The use of reefers as storage facilities can be very useful where no other infrastructure is available, however it is still always advisable to investigate permanent hard sided buildings capable of being retrofitted to maintain the required temperature ranges.

If a reefer container is to be kept as a permanent storage structure, there are a few things to consider:

- **Power** - Wherever possible, reefers should be plugged directly into the power grid, or a large enough generator to maintain the power needs of the unit. Though sea shipments might take months to complete, the on-board motor isn't designed for permanent usage. If the on-board motor is used to maintain a reefer's set point, the output exhaust cannot be into an enclosed space, like a larger warehouse.
- **Interior set up** - Though reefers are used for transport, they are not directly designed for storage. This means that the floors of the container might not be conducive to shelving or rolling handling equipment. Additional flooring may need to be installed to accommodate storage needs.
- **Doors** - Reefer containers were designed to be opened infrequently, and using one as a storage facility may lead to excessive heat loss as the large doors may be opened more frequently. Plastic flaps might need to be installed in the interior to reduce heat loss.
- **Temperature monitoring** - Organisations using a reefer as a storage facility will still want to conduct a heat mapping exercise and develop some type of monitoring to ensure that products are still properly maintained.
- **Foundation Placement** - Organisations using reefer containers as storage should ensure that containers are placed on a raised hard surface (usually concrete foundation) or at the very least hard packed soil on raised ground to prevent rain damage.

Air Transport Containers

Use of active cooling containers for the transport of temperature-controlled medical items by air requires some additional preplanning. Where air transport using passive cooling containers entails handing self-contained insulated containers directly to air carriers, active cooling air transport containers provide powered temperature regulation directly in the container itself, either powered by direct connection to the electrical system of the air frame, or through a dedicated battery solution.

There are a variety of active cooling air transport containers, usually specified to conform to different types of aircraft. The range of active cooling air transport containers can be from smaller standalone crates to specifically shaped [unit load devices \(ULDs\) use in common commercial air transport](#). It is highly unlikely that personnel from a humanitarian aid organisation will ever be involved with loading or handling air transport containers - usually temperature-controlled air transport containers are managed by the ground crew and/or load master, and the equipment itself may only be leased from the manufacturer.

Example temperature-controlled ULD:



Passive Cold Chain Transportation

Passive cold chain transportation methods broadly refer to any method of transportation of cold chain items that does not involve outside power or maintenance. Passive systems are self-contained and are prepared at the point of origin without continued management by the transporter, other than some basic duty of care.

Passive Cold Chain Containers

Some medical related relief items – such as vaccines and other lifesaving medications – rely heavily on passive cold chain containers for transport in humanitarian field settings. Passive cold chain containers are insulated carries, usually with accompanying ice packs and/or freeze packs, which require no external power or mechanical support and are especially useful in humanitarian contexts where persistent electrical connectivity or advanced infrastructure may not be available or actively working. Passive cold chain containers - either single use disposable or reusable depending on the context - and are only meant to keep cargo items in a pre-defined temperature range for a limited period of time, between 12 hours and 120 hours depending on the container and the external ambient temperature. Please note, the actual duration of passive container will depend on the container and the real-world conditions on the ground. For relatively short transit times, such as single day car rides, or movement via helicopters, passive cold chain containers are ideal for transporting small quantities of items.

There are two main type of devices - reusable containers (cold boxes and vaccine carriers) and disposable boxes. Note: the term “disposable” does not mean these types of insulated boxes can only be used one, they only refer to the easily disposable nature of the materials. Disposable insulated boxes are frequently reused multiple times in single operation.

Cold Boxes – Insulated reusable containers that loaded with coolant packs are used to transport supplies between different medical stores or to health facilities. They are also used to temporarily store items when the refrigerator is out of order or being defrosted.

The storage capacity of cold boxes ranges between 5 and 25 Litres and its cold life can vary from a minimum of 48 hours to a minimum of 96 hours (known respectively as “short range” and “long range” cold boxes).



Vaccine Carriers - Insulated reusable containers that, when lined with coolant packs, keep vaccines (and diluents) cold during transportation from health facilities with refrigeration to vaccination sites where refrigeration and ice are not available. They are smaller than cold boxes and therefore easier to carry by a single health worker travelling on foot or by other means, where the combined journey time and immunisation activity ranges from a few hours to a whole day. The storage capacity of vaccine carriers is between 0.1 and 5.0 Litres.



Disposable Insulated Boxes - (also known as Insulated shipping containers) Insulated containers, manufactured in carton or moulded foams such as polyurethane, polyethylene or expanded polystyrene (EPS). Some are designed for single use while others are returnable for reuse. They are used for the transport of items over long distances. Their storage capacity, temperature range, cold life and resistance vary among different solutions: some solutions are suitable for Road transport with hold on times between 36-48 hours while some other solutions are suitable for air transport with hold on times up to 120 hours. One main concern related to

disposable insulated carton boxes is its single-use lifespan and its low-cost material composition of EPS and water-based gel packs, rarely recyclable.



Disposable insulated carton boxes are used by manufacturers to ship products with sensitive cold chain needs around the world. Disposable insulated containers must conform to certain standards, and often have a cold life often with a maximum of 4 days. Insulated containers are regulated by WHO prequalification standards.

Three categories of packaging are used for international air freighting (listed below in decreasing order of bulk):

Class A Packaging is designed to ensure that the temperature of the item does not rise above +8°C for a minimum exposure of 48 hours at an ambient temperature of 43°C.

Class B Packaging is designed to ensure that the temperature of the items does not rise above +30°C for a minimum exposure of 48 hours at an ambient temperature of 43°C. It must also prevent the temperature of the items from dropping below +2°C for a minimum of 48 hours at an ambient temperature of -5°C.

Class C Packaging provides no specific protection against high temperatures. However, it must prevent the temperature of the item from dropping below +2°C for a minimum exposure of 48 hours at an ambient temperature of -5°C.

No matter the type of passive insulated carrier used, it is recommended that each insulated carton should weigh less than 50kg to ensure ease of handling during transport as they are frequently loaded and offloaded manually.

Pallet Shippers

Pallet shippers are passive insulated packaging that is specifically designed to cover or encompass entire pallets of cold chain related items. Pallet shippers can come in the form foam insulation, cardboard, or some form of thermal resistant fabric. Pallet shippers are used mostly by commercial providers shipping bulk volumes of cold chain required medical products.

Example pallet shippers:

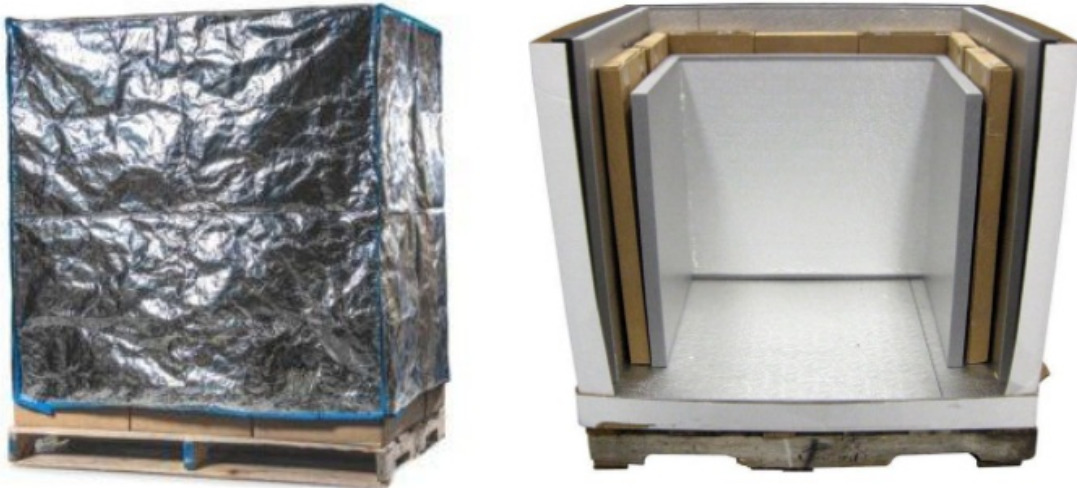

Pallet shippers have a built-in wooden or plastic pallet platform to enable handling and transport by forklift or pallet handling equipment. Pallet shippers will generally accommodate higher volumes per unit. Where used or ordered, it is recommended that external dimensions of pallet shippers should not exceed [standard ISO pallet sizes](#), while also not exceeding not exceed 160 cm in height. Height requirements may vary on the context, but 160 cm is generally the maximum height a pallet can be to fit as a single unit into most aircraft. Shippers should understand the ultimate transport requirements prior to using pallet shippers. Under no circumstance should pallet shippers be depalletized in transport, or double stacked!

Transporting Passive Cold Chain Containers

Irrespective of the method, transportation of passive cold chain containers generally should follow a few key steps:

- Wherever possible, passive cold chain containers and boxes should be covered, and kept away from direct sunlight.
- Containers should be kept away from ambient heat sources of excessive heat (such as engines)
- Transportation times should be kept well within the allotted limit of the passive keep cool container. Ideally, maximum transport times should not exceed 2/3 the anticipated duration of the capacity for the container to keep items cool. In many cases, transport times should also be based on the anticipated return journey times, in case cargo items are rejected or may not be able to offload for a variety of reasons.
- Persons receiving the passive containers should be notified in advance and be waiting at the reception area.
- Depending on the nature of the operation, or the requirements for the cargo items, temperature monitoring devices may be included. For more information on monitoring devices, please reference the section on [temperature monitoring](#) in this guide.

Additionally, a general checklist for transporting passive cold chain containers might include:

Pre-shipment actions:

- Ensure that there are sufficient quantities of all packaging components to accommodate the shipment on the shipping day.
- Ensure that all components have been conditioned to the correct temperature (i.e. temperature-stabilising media, whether frozen or refrigerated). Instructions on conditioning of passive keep cool boxes depends on the type of container used, and usually is different in "summer" and "winter" ambient temperature conditions.
- Ensure that the designated vehicle is in good working order, that its service record is up-to-date, and that the driver has carried out the relevant daily safety inspection.

Shipping day – actions at point of origin:

- Prepare and pack product in its designated secondary or ancillary packaging.
- Assemble the passive shipping system and pack and load the product in accordance with approved site procedures.
- Add temperature dataloggers or temperature indicators if required. Place in close proximity to the product. Do not allow them to come into contact with temperature-stabilising media, such as ice packs.
- Ensure that all paperwork and checklists are completed by the responsible parties.

Actions during transit:

- Where appropriate, vehicles should be parked in a secured parking area during rest stops; wherever possible, vehicles should be parked in the shade.
- Containers must not be opened during transit.

Arrival day: actions at destination:

- Open packaging, remove product from its passive shipping system and move it immediately to the correct temperature-controlled storage conditions.
- Retrieve and deactivate temperature monitors for data retrieval.
- Ensure all checklists and arrival forms are completed by responsible parties.

Post-shipment actions:

- Forward completed checklists to appropriate personnel, including electronic temperature data files.
 - Dispose of, recondition or reuse packaging as appropriate.
-

Adapted from: [WHO - Temperature-controlled Transport Operations by Road and by Air](#)

Planning Passive Keep Cool Container Transport

Use of Portable Passive Keep Cool Containers

Due to infrastructure and logistics constraints in some locations, it is advised to assess the logistics capacity of downstream reception facilities prior to shipping. In case of limited logistics capacity, it is preferable to ship keep cool items using individual insulated cartons.

Reusable containers generally used to transport keep cool items from one fixed store to another, and from central stores to health facilities. They have a storage capacity between 5.0 and 25.0 litres.

Cold Boxes

There are two types of cold boxes:

- Short range: With a minimum cold life of 48 hours.
- Long range: With a minimum cold life of 96 hours.

Vaccine Carriers

Used for transporting vaccines where the combined journey time and immunisation activity ranges from a few hours to a whole day. The vaccine storage capacity of vaccine carriers is between 0.1 and 5.0 litres.

When choosing means for transport of keep cool items, consider the following factors:

- The heat and freeze sensitivity of every keep cool item being transported, especially vaccines. If available, refer to manufacturer indications for further information on temperature sensitivity of the items. In any other case refer to WHO *How to use passive containers and coolant-packs*.
- The required cold life to keep transported keep cool items at safe temperatures for an entire transport or outreach session. For vaccination outreach sessions the considered time should include travel to and from the vaccination site, allowing the safe management of non-used vaccines.
- The required capacity based on the volume of keep-cool items to be transported.

When selecting the appropriate container, the time of transport must be considerably less than the cold life of the container. Unexpected events such as vehicle breakdowns, human error or carelessness, often delay the time of transport. When the duration of the journey exceeds the cold life of the container, it is possible to replace the coolant packs if necessary. The back-up coolant packs can be transported in a separated container or swapped in a stop-by storage facility with compatible coolant packs. It is therefore necessary not to compromise on the number of ice packs which may need to be prepared.

Coolant Packs

Once the decision about the type of container is taken, calculate the number of cold boxes required. Subsequently calculate the number of coolant packs and temperature tracking and alert devices required. Each container holds a specific number of coolant packs.

In regular cold chain management, it is recommended that every cold box or vaccine carrier should have at least two sets of coolant packs, allowing one set of the packs to be cooled, while the other set is being used in the cold box or vaccine carrier. Note that one set of coolant packs is normally provided with each procured cold box or vaccine carrier, so that one additional set at least needs to be ordered.

The type of coolant packs must be selected according to the container and the required temperatures. Ideally, they should be compatible with other coolant packs used in the country.

There are several types of coolant packs:

Water-Filled Coolant Packs	The most commonly used, they are available in a solid rectangular plastic container in different sizes. The most common are: 0.3 litres (in two different sizes: 173x120x26mm and 163x90x34mm), 0.4 litres (163x94x34mm) and 0.6 litres (190x120x34mm). They are used to maintain temperatures in reusable cold boxes or vaccine carriers. WHO currently recommends the use of water-filled coolant packs. Drinking water is safe for such use and is generally available; this makes it the most practical substance for filling coolant packs because both water and ice can effectively control the temperature of the load, when correctly used.
Gel-Packs	sealed coolant containers pre-filled with a mixture of water and additives. They are available in flexible plastic bag or in a rectangular plastic container. WHO does not recommend using gel-packs because their thermal properties - freezing point of some gel-packs can be significantly below 0°C - and their lower durability.
Phase-Change Material Packs (PCM-packs)	containers filled with other phase-change materials different from water. They can be designed to change phase at the convenient temperatures range, overcoming the risk associated with frozen water. However, they are also more expensive, and their conditioning process is longer and more complex.

Depending on the urgency of the item, manufacturers of cold chain and keep cool items ship products by air using coolant-packs of various types and sizes containing various fill materials, including water, gel and PCM. It is a common practice to reuse these coolant packs recovered from international shipping containers. WHO discourages this practice as these packs do not necessarily perform in the same way as the water-packs. In addition, they are not designed for repeated use and may not be dimensionally compatible with most of the passive containers used for the in-country supply chain. The recommendation is that these packs are removed from the receiving keep cool items and recycled or disposed of according to the manufacturer's recommendations and/or national waste management policies.

Conditioning Water-Packs

The temperature of coolant packs must be set according to the temperatures required by the keep cool items to be shipped. There are two main possibilities:

- The items to be shipped in the cold box may be frozen. Examples: vaccines for Measles, Polio, Yellow fever, Meningitis, etc.
- The items to be shipped in the cold box will be irreversibly damaged when frozen. Examples: Oxytocin, vaccines for DTP, DT, Td, TT, Hep A and Hep B, Hib.

To understand if items can be safely frozen or not, consult the manufacturer's guidelines. If all items to be shipped in the cold box may be frozen, frozen coolant packs can be directly transferred from the freezer to the cold box.

In the case that items will be damaged when frozen, the coolant packs need to be "conditioned" before being transferred into the cold box. That means bringing its temperature up to 0°C. The conditioning of coolant packs consists of laying the required number of frozen icepacks on a table or work surface (preferably not under direct sun light) and waiting until they all reach 0°C. This may take at least 30 to 45 minutes in hot weather and much longer in cool conditions (from 90 to 120 minutes at +20°C). In order to know when the icepacks are ready to be used, there must be liquid water inside every pack and the ice cores should be able to move freely inside the packs when shaken. To ease the process, place the icepacks in one

single layer and separated from each other.

The use of cool water-packs and warm water-packs can be pertinent for some shipments. Warm water-packs are used to protect freeze-sensitive items in countries where temperatures are frequently below 0°C. Warm water-packs are to be prepared at a room temperature between +18°C and a maximum of +24°C. Cool water-packs are to be prepared in a refrigerator at a temperature of no more than +5°.

Packing Keep Cool Containers

The first action during packing is to dry any droplets on the coolant packs surface and placing it in a cold box according to the cold box manufacturer specifications: the correct size and number of coolant-packs must be used. The technical sheet for loading the cold box is often available inside each box.

Place the keep cool items inside the cold box, putting cardboard between thermo-sensitive products and icepacks to prevent them touching. Make sure that any remaining space is filled with packing material to avoid damage during onward transport.

When packing keep cool items without secondary package/carton box (common practice when using vaccine carriers), put the items and diluents in a plastic bag in the middle of the cold box or carrier to protect them from damage due to condensation.

Place the required temperature monitoring devices in the box or carrier. Do not allow monitoring devices to come into contact with coolant packs. If using a thermometer in the container, place it in a visible and easily accessible place to avoid long content handling during temperature checks.

When required, put the top layer of coolant packs and close the container.

Calculating Volumes for Vaccine Shipments using Keep Cool Boxes

To calculate the volume of vaccine to be shipped, it is necessary to know for each vaccine and diluent in the shipment:

- The required storage temperature: 3 ranges of temperature are normally considered for vaccine transportation: -15°C to -25°C, +2°C to +8°C or ambient.
- The number of doses to be transported.
- The packed volume per dose (cm³/dose). The packed volume includes the vaccine vial, the packet containing the vaccine vial and any intermediate packaging (secondary packaging).

The maximum recommended packed volume per vaccine dose and diluents are:

Vaccine type	Dose per vial cm³ per dose	
BCG (freeze-dried)	20	1.2
	10	3.0
DTP, DT, Td, TT		

	20	2.0
	2	6.0
DTP-HepB	10	3.0
DTP-Hib	10	2.5
	1	45.0
DTP+Hib (freeze-dried)	10	12.0
	1	22.0
DTP-HepB+Hib (freeze dried)	2	11.0
	1	18.0
	1 in UNIJECT	30.0
	2	13.0
HepB	6	4.5
	10	4.0
	20	3.0
	1	15.0
Hib (liquid)	10	2.5
	1	13.0
Hib (freeze-dried)	2	6.0

	10	2.5
Measles (freeze-dried)	10	3.5
	1	16.0
MMR (freeze-dried)	10	3.0
	10	2.5
MR (freeze-dried)	10	2.5
	20	2.5
Meningitis A&C	50	1.5
	10	2.0
OPV	20	1.0
	1	25.0
TT in UNIJECT	5	6.5
	10	2.5
Yellow fever	20	1.0
	20	0.70
Diluent for BCG	1	35.0
Diluent for Hib	10	3.0
	1	20.0
Diluent for measles, MR, MMR	10	4.0

	20	2.5
Diluent for meningitis A&C		
	50	1.5
	5	7.0
Diluent for yellow fever	10	6.0
	20	3.0
OPV droppers	n/a	17.0 (per unit)
Diluent for BCG	20	0.70

Be aware that the volume obtained from multiplying the packed volume per dose by the number of doses only takes into consideration the primary and the secondary packages: it doesn't include the cold box packaging. Estimating the final transport volume (including the cold box) is necessary to correctly plan the transport means. For this purpose, a transport box bulking factor can be used. The bulking factor depends on the type of vaccine. WHO *Guideline for establishing or improving primary and intermediate vaccine stores*, recommends the following transport box bulking factors:

- BCF, OPV, measles, MMR, MR = 6.0
- Other vaccines = 3.0
- Diluent, droppers = 1.5

Type of Vaccine – The type of vaccine is of key importance because different vaccines have different presentations. The most common are vials (or ampules), however single-dose pre-filled syringes may be used in humanitarian operations. Depending on the vaccine, vials can contain different number of doses, normally 1, 10 or 20 doses. The key variables used to calculate the required volume for vaccine storage and transport are the number of doses to be stored and the estimated volume per dose. The estimated volume per dose (or packed vaccine volume) quantifies the space needed to store or transport vaccines and diluents and will depend on the number of doses per vial, the physical size of the vial or ampule (primary package) and the bulkiness of the external packaging (secondary packages).

Example multi-dose vaccine vial:



Example single-dose pre-filled vaccine syringe:



Some presentations include the diluent in the same packaging as the vaccine. In such cases it is necessary to refrigerate the diluent as well as the vaccine. In all cases, diluents should be refrigerated 24h prior to vaccine preparation. Refrigeration of diluents is normally done in the last step of the vaccine supply chain.

Whenever possible, the packed vaccine volume per dose should be calculated using data from the vaccine manufacturer or supplier. It is also recommended to use the WHO guidance document for vaccine volume calculation: [How to calculate vaccine volumes and cold chain capacity requirements](#).

Transportation of Clinical Samples

Humanitarian logistics personnel may be required to organise the transportation of clinical samples from the outbreak location to a reference laboratory may be required, especially during disease outbreaks, such Ebola Haemorrhagic Fever. The transportation of samples is usually handled by either by the local government, or by a WHO representative, or by a specialised agency tasked with the process in the local context.

Clinical and biological samples are considered "dangerous goods", and transport of these is subject to very strict regulations. Before transporting clinical samples always consult local regulations and international best practice. Commercial air and sea transporters will often have clear guidelines on the transportation of clinical and biological samples – reference the [dangerous good section of this guide](#) for more information. In absence of a clear local

regulation, humanitarian agencies might refer to WHO's "[Guidance on regulations for the transport of Infectious Substances](#)".

Biologic samples are separated into two different categories when prepared for shipping:

Category A	An infectious substance which is transported in a form that, when exposure to it occurs, is capable of causing permanent disability, life-threatening or fatal disease in otherwise healthy humans or animals. If a Category A substance were released from the craft carrying it and/or protective packaging used during the transportation, it could have severe consequences on the health of any humans or animals that came in contact with it.
Category B	Infectious substances that contain biological agents, capable of causing infection in humans or animals, but NOT meeting the criteria for Category A (i.e. the consequences of an infection are not considered severely disabling or life-threatening).

Adapted from: [WHO's - Guidance on regulations for the transport of Infectious Substances](#)

Packaging

Both Category A and Category B substances have their own forms of approved packaging, and all samples must be transported in their respective approved packaging, usually some form of triple packing. Consider that in some contexts, this type of packaging won't be available to be purchased locally. Certain health actors or specialised medical agencies may have stock available.

The system for transporting samples consists of three layers:

1. Primary container containing the sample: Tube or bottle tightly closed and labelled.
2. Secondary container intended to protect the primary container: Waterproof box/tube (Category A) or plastic bag (Category B) with enough absorbent material to absorb all the liquid in case of breakage.
3. Outer packaging intended to protect the secondary container: Reinforced cardboard box with UN labelling.

Example Packaging for "Category A" Biological Samples

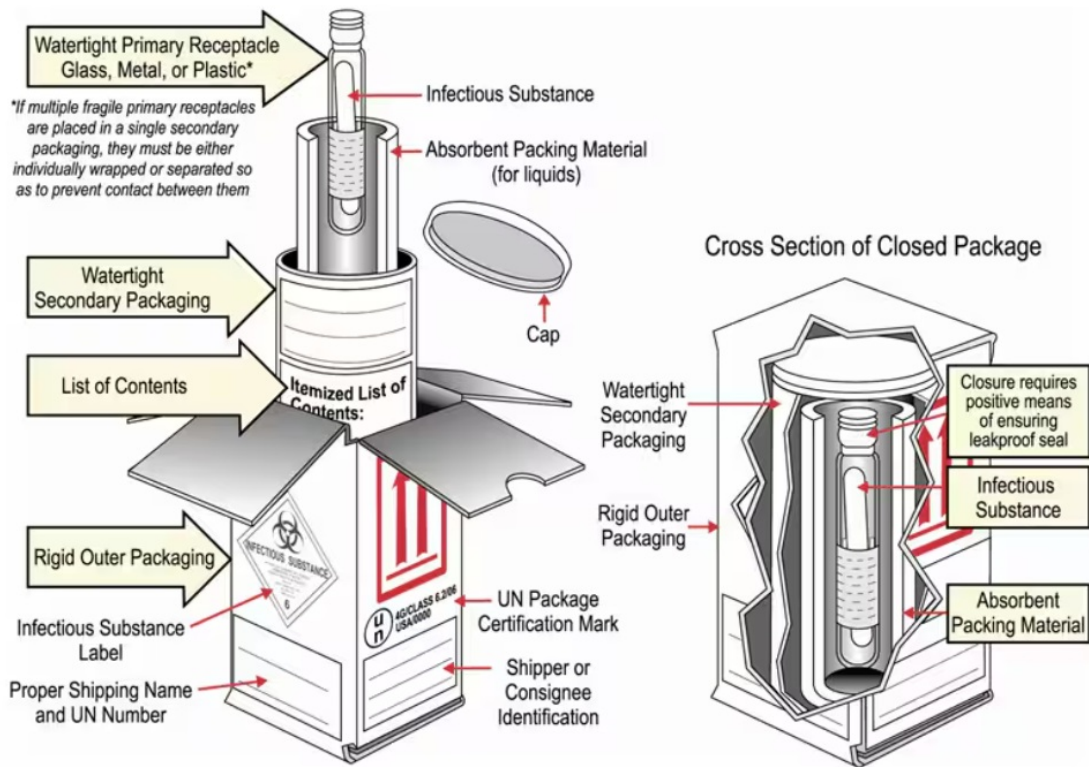

Example Packaging for "Category B" Biological Samples

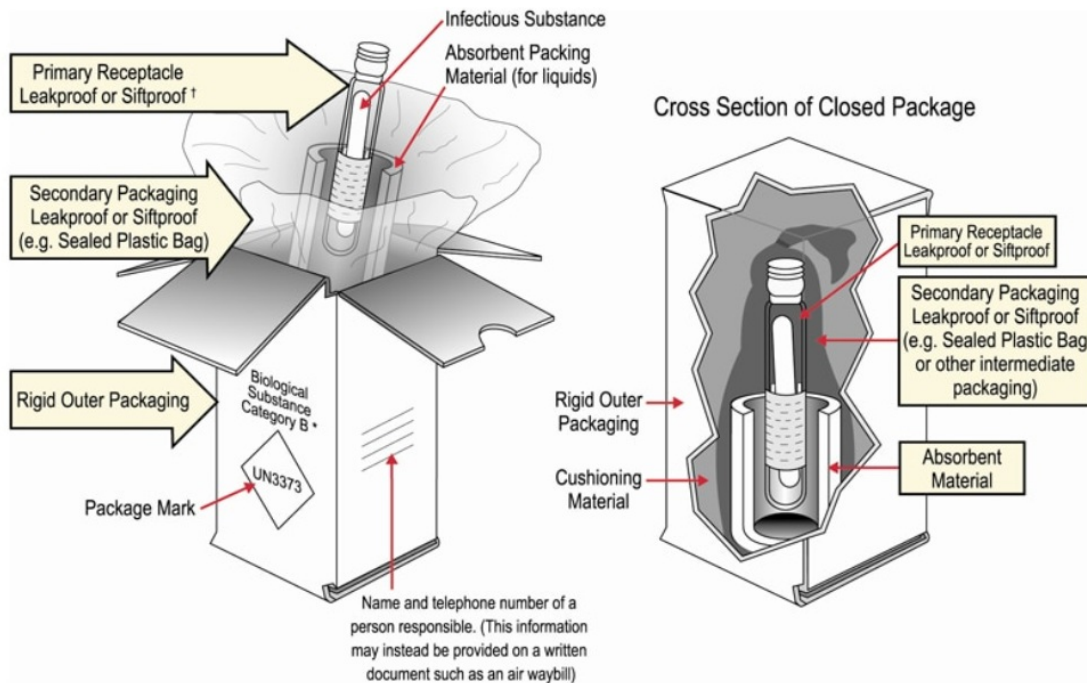

The choice of container depends on the classification of the sample to be transported and whether or not it is necessary to transport the sample at controlled temperature; some samples will require +2°C to +8°C temperature.

Usually, individual transported biological samples will be uniquely identified with information such as the name or patient code number and date/place of collection and will be accompanied by relevant clinical and epidemiological information. Information to be contained on the on the outer packaging of the box should include:

- Shipper.
- Consignee.
- Emergency contact: mention the name and the phone number of the person to contact in case of emergency (i.e., incidental opening or leakage).
- UN approved marking and product category/class.
- Net capacity of sample only.
- Mandatory marking: "Infectious substance" logo and additional required approval markings.

The shipper is responsible for classifying, declaring, packaging and labelling the samples. Any transporter or service provider involved in the transportation chain, must be informed about the material being sent. If there is any problem during the transport, the shipper must be able to prove that he has strictly followed the regulations. If humanitarian organisations organising the transport of biological samples have any questions on labelling, they may also consult their freight forwarder or transport company.

The person enacting the shipment be sure to inform the receiving party in advance, specifying the nature of the sample as well as the planned shipping date to ensure readiness to receive the sample. In some cases, biological samples will be delivered to third party laboratories or government offices who may have very little understanding of the humanitarian operation. Shippers should also tell transport companies well in advance as well, as they may have their own protocols for handling and managing these types of shipments.

Below is a list of UN ID numbers and packing instruction per category that should be included with every shipment.

UN No.	Proper Shipping Name	Category	Hazard Class	Packing Instructions
UN2814	Infectious substance affecting humans	Category A	6.2	620
UN2900	Infectious substances affecting animals	Category A	6.2	620
UN3549	Medical waste, Category A, affecting animals only, solid	Category A	6.2	622
UN3549	Medical waste, Category A, affecting humans, solid.	Category A	6.2	622
UN3291	Biomedical waste, n.o.s., Clinical waste, unspecified, n.o.s. or medical waste, n.o.s. or regulated medical waste, n.o.s.	Category B	6.2	621
UN3373	Biomedical Substance Category B	Category B	6.2	650

More information on identifying dangerous goods categories can be found in the [dangerous goods section of this guide](#).

Health Supply Chain Tools and Resources

Templates and Tools

[TEMPLATE - Cold Chain Temperature Monitoring Chart](#)

Sites and Resources

- [Approved essential medicines per country](#)
- [Basel Convention on the Control of Transboundary Movements of Hazardous Wastes](#)
- [DG ECHO - Review of quality assurance \(QA\) mechanisms for medicines and medical supplies in humanitarian aid](#)
- [ICRC - Medical Waste Management Guidelines](#)
- [Immunizationacademy.com](#)
- [JSI - Guidelines for the Storage of Essential Medicines and other Health Commodities](#)
- [MSF - Cold Chain Evaluation](#)

- [PATH - Total Cost of Ownership Tool for Cold Chain Equipment](#)
- [PATH / WHO - Delivering Vaccines: A Cost Comparison of In-Country Vaccine Transport Container Options](#)
- [Stockholm Convention on Persistent Organic Pollutants \(POPs\)](#)
- [Technical Network for Strengthening Immunization Services](#)
- [USAID - Logistics Handbook, A Practical Guide for the Supply Chain Management of Health Commodities](#)
- [UNICEF - Cold Chain Technical Support](#)
- [UNICEF / WHO - Effective Vaccine Store Management Initiative](#)
- [UNICEF - Procurement Guidelines for Walk-In Cold Rooms And Freezer Rooms](#)
- [UNICEF - Procurement Guidelines, Compression System Refrigerators and Freezers](#)
- [UNICEF - Procurement Guidelines, Solar Direct Drive Refrigerators and Freezers](#)
- [UNICEF - Procurement Guidelines, Temperature Monitoring Devices](#)
- [UNICEF - Procurement Guidelines, Vaccine Carriers and Cold Boxes](#)
- [UNICEF / WHO - Decommissioning and Safe Disposal of Cold Chain Equipment](#)
- [WFP Logistics Cluster - Downstream Logistics in Pandemics](#)
- [WHO - Effective Vaccine Management \(EVM\) model standard operating procedures](#)
- [WHO - Expert Committee on Specifications for Pharmaceutical Preparations](#)
- [WHO - Interagency Emergency Health Kit](#)
- [WHO - Guidelines on the International Packaging and Shipping of Vaccines](#)
- [WHO - Guideline For Establishing Or Improving Primary And Intermediate Vaccine Stores](#)
- [WHO - Guidelines for Medicine Donations](#)
- [WHO - Guidance on Regulations for the Transport of Infectious Substances](#)
- [WHO - How to Monitor Temperatures in the Vaccine Supply Chain](#)
- [WHO - How to calculate vaccine volumes and cold chain capacity requirements](#)
- [WHO - How to use passive containers and coolant-packs, 2015](#)
- [WHO - Introducing Solar-powered Vaccine Refrigerator and Freezer Systems, A Guide for Managers in National Immunization Programmes](#)
- [WHO - Immunization in practice: A practical guide for health staff. Geneva](#)
- [WHO - Model List of Essential Medicines](#)
- [WHO - Performance, Quality and Safety \(PQS\)](#)
- [WHO - Safe Disposal of Unwanted Pharmaceuticals](#)
- [WHO - Safe Management of Wastes from Health-Care Activities](#)
- [WHO - Solar direct-drive vaccine refrigerators and freezers](#)
- [WHO - Selection of Essential Medicines at Country Level](#)
- [WHO - Study protocol for temperature monitoring in the vaccine cold chain](#)
- [WHO - Supplement 01 - Selecting sites for storage facilities - May 2015](#)
- [WHO - Supplement 02 - Design of storage facilities - May 2015](#)
- [WHO - Supplement 03 - Estimating the capacity of storage facilities - May 2015](#)
- [WHO - Supplement 04 - Security and fire protection in storage facilities - May 2015](#)
- [WHO - Supplement 05 - Maintenance of storage facilities - May 2015](#)
- [WHO - Supplement 06 - Temperature and Humidity Monitoring Systems for Fixed Storage Areas - May 2015](#)
- [WHO - Supplement 07 - Qualification of Temperature-controlled Storage Areas - May 2015](#)
- [WHO - Supplement 08 - Temperature Mapping of Storage Areas - May 2015](#)
- [WHO - Supplement 09 - Refrigeration equipment maintenance - May 2015](#)
- [WHO - Supplement 10 - Checking the accuracy of temperature control and monitoring devices - May 2015](#)
- [WHO - Supplement 11 - Qualification of refrigerated road vehicles - May 2015](#)
- [WHO - Supplement 12 - Temperature-controlled Transport Operations by Road and by Air - May 2015](#)

- [WHO - Supplement 13 - Qualification of shipping containers - May 2015](#)
- [WHO - Supplement 14 - Transport route profiling qualification - May 2015](#)
- [WHO - Supplement 15 - Temperature and humidity monitoring systems for transport operations - May 2015](#)
- [WHO - Supplement 16 - Environmental management of refrigerant gases and refrigeration equipment - May 2015](#)
- [WHO - Thermostability of vaccines](#)
- [WHO - User's handbook for vaccine cold rooms and freezer rooms](#)